

TEST REPORT FIRES-FR-171-10-AUNE

Cable bearing system BAKS with cables business BITNER



This is an electronic version of a test report which was made as a copy of test report officially issued in a paper form. The electronic version of a test report shall be used only for informative purposes. Any information listed in this test report is the property of the sponsor and shall not be used or published without written permission. Contents of this file may only be modified by the editor i.e. Testing laboratory FIRES s.r.o. Batizovce. Sponsor is allowed to publish this test report in parts only with written permission of the editor.



1. INTRODUCTION

This test report contains the results of test carried out by testing laboratory of FIRES, s.r.o. in Batizovce. The purpose of the test was acquirement of information for product classification.

Representative from the sponsor's side witnessing the test:

Mr. Jacek Kliczek	BAKS Kazimierz Sielski
Mr. Piotr Okniński	BAKS Kazimierz Sielski
Mr. Marcin Tokaj	ZAKLADY KABLOWE BITNER
Mr. Tomasz Latacz	ZAKLADY KABLOWE BITNER
Mr. Bartosz Nitkiewicz	ZAKLADY KABLOWE BITNER

test directed by	Ing. Štefan Rástocký
test carried out by	Miroslav Hudák
operator	Alexander Reľovský

2. MEASURING EQUIPMENT

Identification number	Measuring equipment	Note
F 90 004	Vertical test furnace for fire resistance testing	-
F 69 005	PLC system for data acquisition and control TECOMAT NS 950	-
F 40 008	SW Control Web 2000	-
F 40 009	Control and communication software to PLC TECOMAT NS 950	-
F 40 010	Visual and calculating software to PLC TECOMAT NS 950	-
F 40 011	Driver Tecomat – CW 2000 (SW)	-
F 69 009	PLC system for data acquisition and climate control TECOMAT TC 604	-
F 60 001 - F 60 009	Sensors of temperature and relative air humidity	climatic conditions measuring
F 71 008, F 71 009	Transducer of differential pressure (-50 to + 150) Pa	pressure inside the test furnace
F 08 521 - F 08 528	Plate thermometers	temperature inside the test furnace, according to EN 1363-1
F 08 701	Sheathed thermocouple type K Ø 3 mm	ambient temperature
F 54 020	Digital calliper (0 to 200) mm	-
F 54 059	Racking meter	-
F 57 007	Digital stop-watch	-
F 96 015	Test signal panel	-

3. PREPARATION OF THE SPECIMEN

Testing laboratory didn't take off individual components of the specimen. Components take-off and its delivering to the testing laboratory were carried out by the test sponsor. Assembling of the supporting system into the test furnace and mounting of cables and weights into the supporting system was carried out by workers businesses BAKS Kazimierz Sielski and ZAKLADY KABLOWE BITNER.



4. PREPARATION OF THE TEST

4.1 DESCRIPTION OF THE SPECIMEN STRUCTURE

Test specimen comprised from cable bearing system BAKS Kazimierz Sielski – cable trays, cable ladders, cable clips UKO1, OZO, UDF, OZSO, UEF and with accessories and power and communication non-halogen cables made by ZAKLADY KABLOWE BITNER.

Cables used during to course of test:

NHXH FE180/E90 4x1,5 RE	(8 x)
NHXCH FE180/E90 4x1,5 RE/1,5	(10 x)
NHXH FE180/E90 4x50 RM	(8 x)
NHXCH FE180/E90 4x50 RM/25	(10 x)
NHXH FE180/E90 4x4,0 RE	(2 x)
JE-H(St)H FE180/E90 2x2x0,8	(6 x)
HTKSHekw FE180/E90 1x2x0,8	(16 x)
HDGs FE180/E90 4x1,0 RE	(20 x)
HDGs FE180/E90 4x4,0 RE	(18 x)
HDGsekwf FE180/E90 4x1,0 RE	(4 x)
HDGsekwf FE180/E90 4x4,0 RE	(4 x)
HLGs FE180 FE180/E90 4x1,0	(2 x)
(N)HXH FE180/E90 4x1,5 RE	(4 x)
(N)HXH FE180/E90 5x50 RM	(2 x)
Securi Flame F 1x2x0,75	(2 x)

The length of cables was 5 m, length of 3,5 m was exposed to fire. Cables were fixed to the cable trays by steel clamps UDF..., to the cable ladders by steel clips UK01/..., in the points of allowed bending radius according to the cable diameter.

Loadbearing system consisted of cable tracks 4,5 m long and of ceiling installation (steel members made of galvanized steel). Length of trays exposed to fire was 3,5 m.

Suspension track No. 1 and 7

Suspension was made of two cable trays KCOP400H60/3N, (400 x 60) mm (width x height), steel sheet thickness 1,5 mm, joined in distance of 600 mm from middle support with joint members LDOCH60N with screws SGN M6x12. Cable trays were fixed to support hangers WWCTO400 with screws SGN M6x12. Support hangers were fixed to hangers WPCEO800 with screws SMM 10x100. Three hangers with support hangers were used for this track, in the middle of furnace and in distance of 1200 mm from the middle hanger. Hangers were fixed to ceiling with screws PSROM10x80. Loading of trays was 10 kg.m⁻¹.

Cables used for track No. 1:

2 x NHXH FE180/E90 4x50 RM
 2 x NHXH FE180/E90 4x1,5 RE
 2 x JE-H(St)H.. RE FE180/E90 2x2x 0.8
 2 x HTKSHekw FE180/E90 1x2x0,8

Cables used for track No. 7:

2 x NHXCH FE180/ E90 4x50/25 RM
 2 x NHXCH FE180/E90 4x1,5/1,5 RE
 2 x HDGs FE180/E90 4x4,0 RE
 2 x HDGs FE180/E90 4x1,0 RE

**Suspension track No. 2 and 8**

Suspension was made of two cable ladders DUOP400H60/3N, (400 x 60) mm (width x height), joined in distance of 600 mm from middle support with joint members LDONCH60N with screws SGN M8x14. Span of transoms is 300 mm. Cable ladders were fixed to support hangers WWCTO400 with screws SGN M6x12. Support hangers were fixed to hangers WPCEO800 with screws SMM 10x100. Three hangers with support hangers were used for this track, in the middle of furnace and in distance of 1200 mm from the middle hanger. Hangers were fixed to ceiling with screws PSROM10x80. Loading of ladders was 20 kg.m⁻¹.

Cables used for track No. 2:

2 x NHXH FE180/E90 4x50 RM
2 x NHXH FE180/E90 4x1,5 RE
2 x JE-H(St)H.. RE FE180/E90 2x2x 0.8
2 x HTKSHekw FE180/E90 1x2x0,8

Cables used for track No. 8:

2 x NHXCH FE180/ E90 4x50/25 RM
2 x NHXCH FE180/E90 4x1,5/1,5 RE
2 x HDGs FE180/E90 4x4,0 RE
2 x HDGs FE180/E90 4x1,0 RE

Suspension track No. 3 and 5

Suspension was made of two cable trays KCOP400H60/3N, (400 x 60) mm (width x height), steel sheet thickness 1,5 mm, joined in distance of 750 mm from middle support with joint members LDOCH60N with screws SGN M6x12. Cable trays were fixed to support hangers WFLO400 with screws SGN M6x12. Support hangers were fixed from one side to hangers made of two parts – WFLO600 and WFLO200, which were screwed together with screws SMM10x60. Second side was supported with threaded bar PGM10 with screws NSM10 and washer PP10. Three hangers with support hangers were used for this track, in the middle of furnace and in distance of 1500 mm from the middle hanger. Hangers were fixed to ceiling with screws PSROM10x80 and TRSOM10. Loading of trays was 10 kg.m⁻¹.

Cables used for track No. 3:

2 x (N)HXH FE180/E90 5x50 RM
2 x (N)HXH FE180/E90 4x1,5 RE
2 x HDGs FE180/E90 4x4,0 RE
2 x HDGs FE180/E90 4x1,0 RE

Cables used for track No. 5:

2 x NHXH FE180/E90 4x4,0 RE
2 x HDGs FE180/E90 4x1,0 RE
2 x HDGs FE180/ E90 4x4,0 RE
2 x HDGsekwf FE180/ E90 4x4,0 RE
2 x HDGsekwf FE180/E90 4x1,0 RE

Suspension track No. 4 and 6

Suspension was made of two cable ladders DUOP400H60/3N, (400 x 60) mm (width x height), joined in distance of 750 mm from middle support with joint members LDONCH60N with screws SGN M8x14. Span of transoms is 300 mm. Cable ladders were fixed to support hangers WFLO400 with screws SGN M6x12. Support hangers were fixed from one side to hangers made of two parts – WFLO600 and WFLO200, which were screwed together with screws SMM10x60. Second side was supported with threaded bar PGM10 with screws NSM10 and washer PP10. Three hangers with support hangers were used for this track, in the middle of furnace and in distance of 1500 mm from the middle hanger. Hangers were fixed to ceiling with screws PSROM10x80 and TRSOM10. Loading of ladders was 20 kg.m⁻¹.



Cables used for track No. 4:

2 x NHXCH FE180/E90 4x50/25 RM
2 x NHXCH FE180/E90 4x1,5/1,5 RE
2 x HDGs FE180/E90 4x4,0 RE
2 x HDGs FE180/E90 4x1,0 RE

Cables used for track No. 6:

2 x (N)HXH FE180/E90 4x1,5 RE
2 x HDGs FE180/E90 4x1,0 RE
2 x HLGs FE180/E90 4x1,0 RE
2 x HTKSHekw FE180/E90 1x2x0,8
2 x HDGsekwf FE180/ E90 4x4,0 RE
2 x HDGsekwf FE180/E90 4x1,0 RE

Ceiling installation

Installation of cables was made with clips UKO1 which were fixed to steel profiles SDOP 800 (suspension track No. 9), holders OZO (suspension track No. 10), steel clamps UDF, UEF (suspension tracks No. 11, 13, 14) and holders OZSO (suspension track No. 12).

Steel profiles (type SDOP 800) in track 9 were fixed to ceiling by dowels (type SRO M6x30) in spacing of 600 mm.

Holders OZO in track 10 were fixed to ceiling by dowels (type SBO M5x60) in spacing of 600 mm.

Steel clamps UDF in track 11 were fixed to ceiling by dowels (type KWBO 6x35) in spacing of 600 mm.

Holders OZSO in track 12 were fixed to ceiling by dowels (type SBO M5x60) in spacing of 600 mm.

Steel clamps UEF in track 13 were fixed to ceiling by dowels (type KWBO 6x35) in spacing of 600 mm.

Steel clamps UDF x2 in track 14 were fixed to ceiling by dowels (type GSO M6x40) in spacing of 600 mm.

Cables used for track No. 9:

2 x HTKSHekw FE180/90 1x2x0,8
2 x HDGs FE180/E90 4x1,0 RE
2 x HDGs FE180/E90 4x4,0 RE

Cables used for track No. 10:

2 x NHXH FE180/ E90 4x50 RM
2 x NHXCH FE180/ E90 4x50/25 RM
2 x NHXH FE180/ E90 4x1,5 RE
2 x NHXCH FE180/E90 4x1,5/1,5 RE

Cables used for track No. 11:

2 x HTKSHekw FE180/90 1x2x0,8

Cables used for track No. 12:

2 x JE-H(St)H.. RE FE180/ E90 2x2x 0.8
2 x HTKSHekw FE180/90 1x2x0,8
2 x HDGs FE180/E90 4x1,0 RE
2 x HDGs FE180/E90 4x4,0 RE

Cables used for track No. 13:

2 x HTKSHekw FE180/90 1x2x0,8
2 x HDGs FE180/E90 4x1,0 RE
2 x HDGs FE180/E90 4x4,0 RE



Cables used for track No. 14:

2 x NHXH FE180/ E90 4x50 RM
 2 x NHXCH FE180/ E90 4x50/25 RM
 2 x NHXH FE180/ E90 4x1,5 RE
 2 x NHXCH FE180/E90 4x1,5/1,5 RE
 2 x HTKSHekw FE180/90 1x2x0,8
 2 x HDGs FE180/E90 4x1,0 RE
 2 x HDGs FE180/E90 4x4,0 RE
 2 x Securi Flame F 1x2x0,75

Types of individual components are from catalogue BAKS.
 Cable penetration through the wall of test furnace was sealed by mineral wool Rockwool.
 Loading with steel chain were used as the equivalent load.

More detailed information about construction of specimen is shown in the drawings which form an integral part of this test report. Drawings were delivered by sponsor.

All the information about technical specifications of used materials and semi-products, information about their type sign were delivered by sponsor. This information was not subject of the inspection of specimen. Parameters which were checked are quoted in paragraph 4.3.

4.2 DESCRIPTION OF SPECIMEN FIXATION

The test specimen was fixed on the ceiling of the test furnace which was created from concrete panels made of common shocked concrete of class B 20, 150 mm thick.
 The type of specimen fixation into the test furnace is visible in drawing documentation and it was selected by the sponsor.

4.3 INSPECTION OF SPECIMEN

Before and after the function in fire test, conformity of drawings and test specimen was checked. Specimen corresponded to the drawings which create the appendix of this test report. Inspection of specimen consisted of visual review of the test specimen, used materials as well as size verification (number and cross sections of conductors, thickness, measurements of cables and trays) and also the way of specimen fixation to supporting construction was subject of inspection.

4.4 CLIMATIC CONDITIONING OF SPECIMEN

Test specimen was stored in the climatic hall of testing laboratory and was conditioned according to EN 1363-1 under the following climatic conditions:

Ambient air temperature [°C]

mean	22,6
standard deviation	0,5

Relative air humidity [%]

mean	48,5
standard deviation	3,0

The humidity equilibrium state of test specimen was not determined. The test specimen did not comprise hygroscopic material.



5. CARRYING OUT OF THE TEST

5.1 TEST GENERALLY

The test was carried out in horizontal test furnace with dimensions (3500 x 3000 x 2750) mm (length x width x height).

5.2 CONDITIONS OF THE TEST

Conditions in the test furnace (temperature – standard temperature/time curve, pressure, content of O₂) as well as in the testing room (ambient temperature) corresponded to EN 1363-1 and 4102-2 during the test. Detailed information is shown in appendices of this report, or in Quality records of the testing laboratory.

Values characterizing environment in the testing room directly before the test:

Date of the test	Relative air humidity [%]	Ambient air temperature [°C]
16. 09. 2010	55,5	19,1

5.3 RESULTS OF THE TEST

Measured values are stated in appendices of this test report.

5.4 EVALUATION OF THE TEST

Specimen No.	Cables	Track	Time to first failure / interruption of conductor
1	2 cables HDGs FE180/E90 4x1,0 RE		7 minutes
2	2 cables HDGs FE180/E90 4x4,0 RE		11 minutes
3	2 cables NHXCH FE180/E90 4x1,5/1,5 RE		91 minutes no failure / interruption
4	2 cables NHXCH FE180/ E90 4x50/25 RM		91 minutes no failure / interruption
5	2 cables HDGs FE180/E90 4x1,0 RE		44 minutes
6	2 cables HDGs FE180/E90 4x4,0 RE		52 minutes
7	2 cables NHXCH FE180/E90 4x1,5/1,5 RE		91 minutes no failure / interruption
8	2 cables NHXCH FE180/ E90 4x50/25 RM		91 minutes no failure / interruption
9	2 cables HDGs FE180/E90 4x4,0 RE		91 minutes no failure / interruption
10	2 cables HDGs FE180/E90 4x1,0 RE		38 minutes
11	2 cables NHXCH FE180/E90 4x1,5/1,5 RE		91 minutes no failure / interruption
12	2 cables NHXH FE180/ E90 4x1,5 RE		91 minutes no failure / interruption
13	2 cables NHXCH FE180/ E90 4x50/25 RM		91 minutes no failure / interruption
14	2 cables NHXH FE180/ E90 4x50 RM		91 minutes no failure / interruption
15	2 cables HDGsekwf FE180/E90 4x1,0 RE		6 minutes
16	2 cables HDGsekwf FE180/ E90 4x4,0 RE		11 minutes
17	2 cables HLGs FE180/E90 4x1,0 RE		11 minutes
18	2 cables HDGs FE180/E90 4x1,0 RE		45 minutes
19	2 cables (N)HXH FE180/E90 4x1,5 RE		88 minutes
20	2 cables HDGsekwf FE180/E90 4x1,0 RE		13 minutes
21	2 cables HDGsekwf FE180/ E90 4x4,0 RE		17 minutes
22	2 cables HDGs FE180/ E90 4x4,0 RE		91 minutes no failure / interruption
23	2 cables HDGs FE180/E90 4x1,0 RE		91 minutes no failure / interruption
24	2 cables NHXH FE180/E90 4x4,0 RE		91 minutes no failure / interruption
25	2 cables HDGs FE180/E90 4x4,0 RE		91 minutes no failure / interruption
26	2 cables HDGs FE180/E90 4x1,0 RE		91 minutes no failure / interruption
27	2 cables HDGs FE180/E90 4x4,0 RE		73 minutes
28	2 cables HDGs FE180/E90 4x1,0 RE		73 minutes
29	2 cables HDGs FE180/E90 4x1,0 RE		13 minutes
30	2 cables HDGs FE180/E90 4x4,0 RE		47 minutes
31	2 cables NHXCH FE180/E90 4x1,5/1,5 RE		91 minutes no failure / interruption



Specimen No.	Cables	Track	Time to first failure / interruption of conductor
32	2 cables NHXCH FE180/E90 4x50/25 RM		91 minutes no failure / interruption
33	2 cables HDGs FE180/E90 4x1,0 RE		52 minutes
34	2 cables HDGs FE180/E90 4x4,0 RE		91 minutes no failure / interruption
35	2 cables (N)HXH FE180/E90 4x1,5 RE		91 minutes no failure / interruption
36	cable (N)HXH FE180/E90 5x50 RM		91 minutes no failure / interruption
37	cable (N)HXH FE180/E90 5x50 RM		91 minutes no failure / interruption
38	2 cables NHXCH FE180/E90 4x1,5/1,5 RE		91 minutes no failure / interruption
39	2 cables NHXH FE180/ E90 4x1,5 RE		91 minutes no failure / interruption
40	cable NHXCH FE180/ E90 4x50/25 RM		91 minutes no failure / interruption
41	cable NHXCH FE180/ E90 4x50/25 RM		91 minutes no failure / interruption
42	cable NHXH FE180/ E90 4x50 RM		91 minutes no failure / interruption
43	cable NHXH FE180/ E90 4x50 RM		91 minutes no failure / interruption
44	2 cables NHXH FE180/E90 4x1,5 RE		90 minutes
45	cable NHXH FE180/E90 4x50 RM		91 minutes no failure / interruption
46	cable NHXH FE180/E90 4x50 RM		91 minutes no failure / interruption
47	2 cables NHXH FE180/E90 4x1,5 RE		91 minutes no failure / interruption
48	cable NHXH FE180/E90 4x50 RM		91 minutes no failure / interruption
49	cable NHXH FE180/E90 4x50 RM		91 minutes no failure / interruption
50	2 cables HDGs FE180/E90 4x4,0 RE		86 minutes
51	2 cables HDGs FE180/E90 4x1,0 RE		91 minutes no failure / interruption

Signal Cables

Specimen No.	Cables	Track	Time to first failure / interruption of conductor
52	2 cables Securi Flame F 1x2x0,75		91 minutes no failure / interruption
53	2 cables HTKSHekw FE180/90 1x2x0,8		91 minutes no failure / interruption
54	2 cables HTKSHekw FE180/E90 1x2x0,8		91 minutes no failure / interruption
55	2 cables HTKSHekw FE180/90 1x2x0,8		91 minutes no failure / interruption
56	2 cables HTKSHekw FE180/90 1x2x0,8		91 minutes no failure / interruption
57	cable JE-H(St)H.. RE FE180/ E90 2x2x 0.8		91 minutes no failure / interruption
58	cable JE-H(St)H.. RE FE180/ E90 2x2x 0.8		91 minutes no failure / interruption
59	2 cables HTKSHekw FE180/90 1x2x0,8		91 minutes no failure / interruption
60	2 cables HTKSHekw FE180/E90 1x2x0,8		91 minutes no failure / interruption
61	cable JE-H(St)H.. RE FE180/E90 2x2x 0.8		48 minutes
62	cable JE-H(St)H.. RE FE180/E90 2x2x 0.8		64 minutes
63	2 cables HTKSHekw FE180/E90 1x2x0,8		91 minutes no failure / interruption
64	cable JE-H(St)H.. RE FE180/E90 2x2x 0.8		91 minutes no failure / interruption
65	cable JE-H(St)H.. RE FE180/E90 2x2x 0.8		91 minutes no failure / interruption
66	2 cables HTKSHekw FE180/90 1x2x0,8		91 minutes no failure / interruption

The fire test was discontinued in 92nd minute at the request of test sponsor.

Specimens S1 – S51 were tested by three-phase voltage supply 3 x 230/400V with bulbs 240V / 60 W.
Specimens S52 – S66 were tested by one-phase voltage supply 1 x 110V with LED diodes 3V /0,03W.
Circuit breakers with rating 3 A were used.



6. CLOSING

- § This report details the method of construction, the test conditions and results obtained when the specific element of construction described herein was following the procedure outlined in EN 1363-1, and where appropriate DIN 4102-2. Any significant deviation with respect to size, constructional details, loads, stresses, edge or end conditions other than those allowed under the field of direct application in the relevant test method is not covered by this report.
- § Because of the nature of the fire resistance testing and consequent difficulty in quantifying the uncertainty of measurement of fire resistance, it is not possible to provide a stated degree of accuracy of the result.
- § The test results refer only to the tested subjects. This test report is not an approval of the tested product by the test laboratory or the accreditation body overseeing the laboratory's activities. The test was carried out on testing equipment that is the property of FIRES, s.r.o., Batizovce. Without the written permission of the test laboratory this test report may be copied and/or distributed only as the whole. Any modifications of the test report can be made only by the fire resistance test laboratory FIRES, s.r.o., Batizovce.

Issued by:

Responsible for the technical side of the test report:

Ing. Štefan Rástocký
leader of the testing laboratory



Miroslav Hudák
technician of the testing laboratory

7. NORMATIVE REFERENCES

STN EN 1363-1: 2001	Fire resistance tests. Part 1: General requirements
DIN 4102 – 2:1977-09	Fire behaviour of building materials and elements - requirements and testing
DIN 4102 – 12:1998-11	Fire resistance of electric cable systems required to maintain circuit integrity

8. LIST OF APPENDICES

Appendix 1	Measured values inside the test furnace
Appendix 2	Measured values inside the test furnace/graph
Appendix 3	Measured times of tested specimens from S1 to S10
Appendix 4	Measured times of tested specimens from S11 to S20
Appendix 5	Measured times of tested specimens from S21 to S30
Appendix 6	Measured times of tested specimens from S31 to S40
Appendix 7	Measured times of tested specimens from S41 to S51
Appendix 8	Measured times of tested specimens from S52 to S61
Appendix 9	Measured times of tested specimens from S62 to S66
Appendix 10-16	Photos taken before and after the fire test
Appendix 17-68	Drawings

Measured values inside the test furnace

Time t [min]	Temperature [°C]											Deviation d _e [%]	Pressure p [Pa]
	Td1	Td2	Td3	Td4	Td5	Td6	Td7	Td8	Tave	Tn	To		
0	53,2	51,1	39,4	34,6	33,7	33,9	35,7	38,1	40,0	70,4	18,6	0,0	17,3
5	655,2	647,4	613,9	519,2	647,7	626,6	551,4	498,1	594,9	576,4	18,6	-1,8	18,4
10	707,8	706,3	676,3	601,5	710,7	699,7	629,5	590,4	665,3	678,4	18,6	-1,9	14,8
15	755,3	751,2	726,1	647,7	772,1	768,0	696,5	658,9	722,0	738,7	18,5	-2,0	15,0
20	787,6	789,8	788,0	716,9	805,9	808,6	753,3	720,7	771,3	781,4	18,6	-1,8	15,9
25	842,2	838,1	819,5	756,9	857,4	851,1	789,3	760,1	814,3	814,6	18,6	-1,4	15,5
30	870,4	869,2	859,9	799,1	883,9	879,4	826,5	803,4	849,0	841,8	18,5	-1,0	16,6
35	897,9	895,7	887,9	828,4	913,9	908,3	860,3	840,5	879,1	864,8	18,3	-0,6	16,0
40	910,8	908,7	917,9	861,5	931,9	931,7	897,6	879,4	904,9	884,7	18,2	-0,2	14,2
45	926,8	926,1	937,4	887,7	948,4	951,7	930,9	912,6	927,7	902,3	18,2	0,2	16,1
50	949,1	947,0	954,8	911,6	971,5	975,8	948,8	939,1	949,7	918,1	18,0	0,6	16,3
55	966,4	962,8	974,0	936,7	991,6	997,2	981,1	971,0	972,6	932,3	18,1	1,0	16,2
60	964,4	961,8	972,6	953,3	990,9	998,7	995,7	989,7	978,4	945,3	18,0	1,2	15,9
65	971,4	968,4	979,5	963,2	995,9	1003,7	1001,3	1001,9	985,7	957,3	17,9	1,4	17,3
70	979,7	981,0	990,2	973,6	1004,0	1013,2	1007,4	1011,9	995,1	968,4	17,9	1,5	16,6
75	990,2	990,2	1001,8	991,4	1014,6	1025,2	1014,8	1021,1	1006,2	978,7	17,8	1,6	15,9
80	997,0	994,2	1007,4	993,4	1020,6	1032,6	1024,5	1027,8	1012,2	988,4	17,7	1,6	15,7
85	1008,5	1007,8	1018,1	1005,1	1031,0	1043,4	1045,5	1039,8	1024,9	997,4	17,7	1,7	15,0
90	1016,7	1015,8	1027,9	1014,0	1039,4	1052,7	1055,6	1048,2	1033,8	1006,0	17,7	1,8	17,0
91	1020,8	1021,7	1031,4	1016,2	1043,3	1056,9	1057,7	1051,1	1037,4	1007,6	17,7	1,8	15,3

- Tave** Average temperature in the test furnace calculated from plate thermometers
- Tn** Standard temperature in the test furnace laid down to test guideline
- To** Ambient temperature
- d_e** Deviation of the average temperature from the standard temperature calculated according to test guideline
- p** Pressure inside the test furnace measured under the ceiling of the test furnace

Layout of measuring points inside the test furnace:

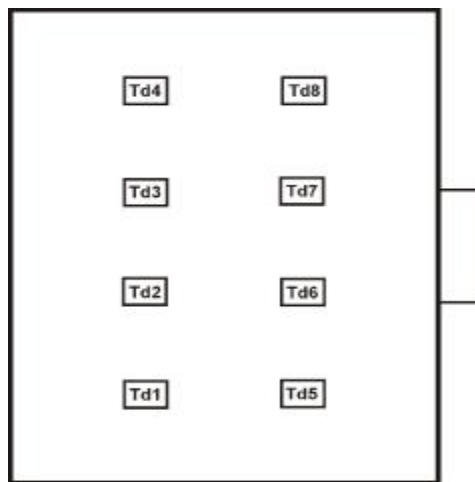

Measured values inside the test furnace / graph

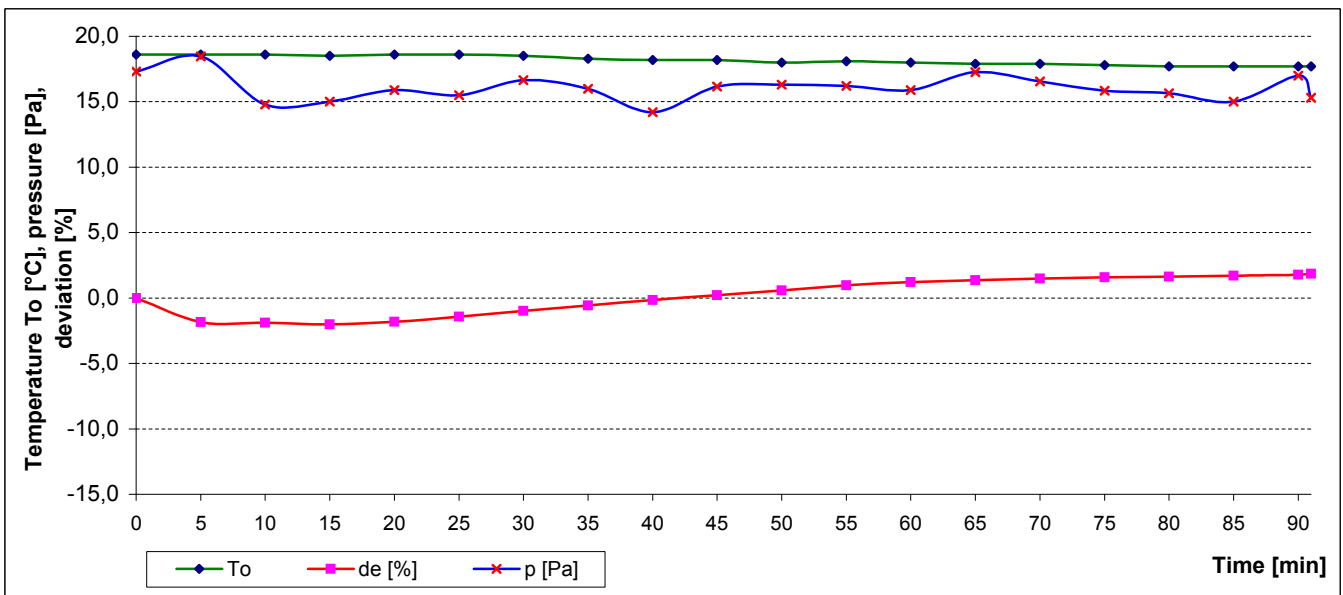
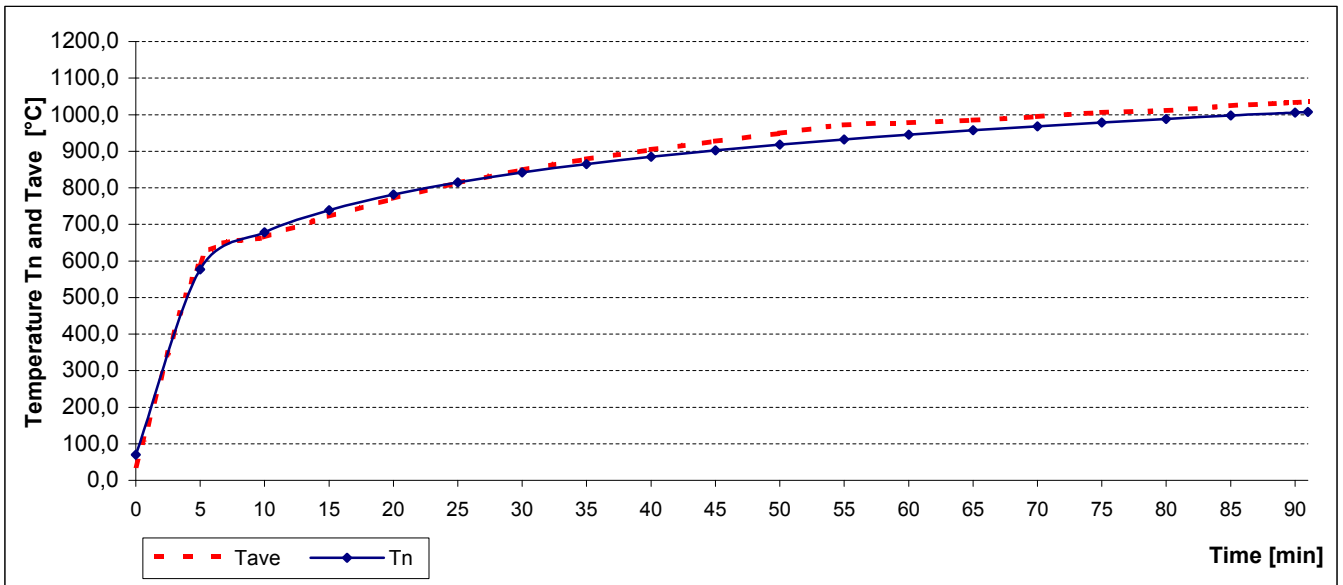
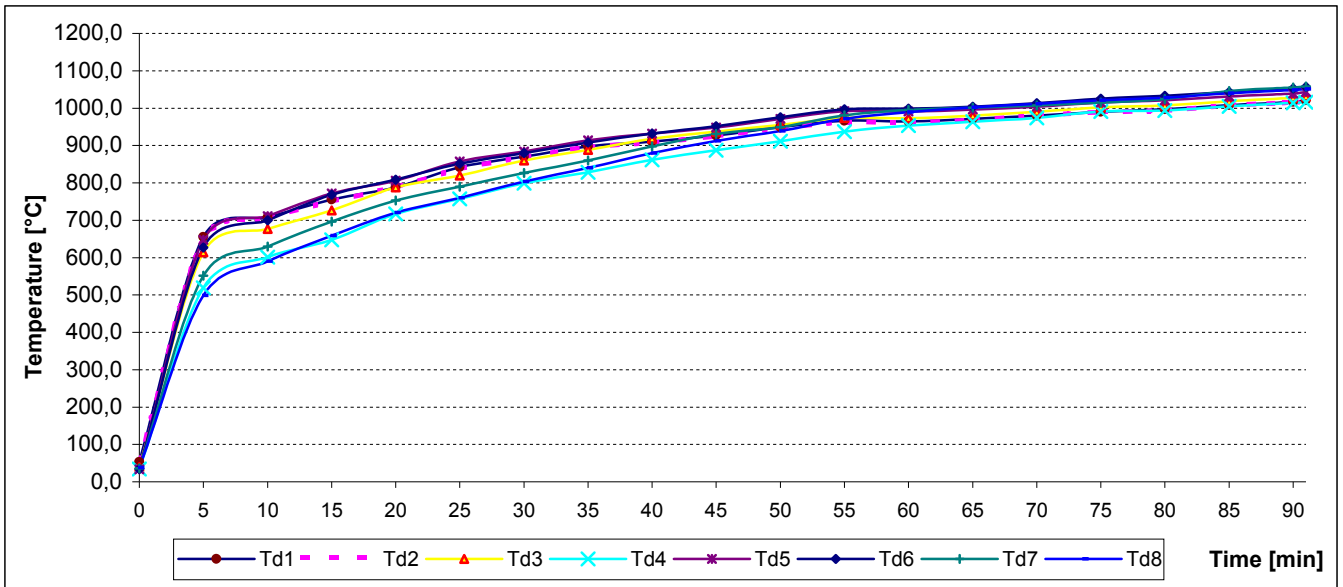

Measured time of tested specimens from S1 to S10

Specimen	Bulbs	Time to permanent failure / interruption [min:s]
S1	1-L1	x
	2-L2	x
	3-L3	7:51
	4-PEN	x
S2	5-L1	x
	6-L2	x
	7-L3	11:29
	8-PEN	x
S3	9-L1	no failure / interruption
	10-L2	no failure / interruption
	11-L3	no failure / interruption
	12-PEN	no failure / interruption
S4	13-L1	no failure / interruption
	14-L2	no failure / interruption
	15-L3	no failure / interruption
	16-PEN	no failure / interruption
S5	17-L1	x
	18-L2	x
	19-L3	44:36
	20-PEN	x
S6	21-L1	52:41
	22-L2	x
	23-L3	x
	24-PEN	x
S7	25-L1	no failure / interruption
	26-L2	no failure / interruption
	27-L3	no failure / interruption
	28-PEN	no failure / interruption
S8	29-L1	no failure / interruption
	30-L2	no failure / interruption
	31-L3	no failure / interruption
	32-PEN	no failure / interruption
S9	33-L1	no failure / interruption
	34-L2	no failure / interruption
	35-L3	no failure / interruption
	36-PEN	no failure / interruption
S10	37-L1	38:40
	38-L2	38:40
	39-L3	38:40
	40-PEN	x

Specimen No.	Cables
1	2 cables HDGs FE180/E90 4x1,0 RE
2	2 cables HDGs FE180/E90 4x4,0 RE
3	2 cables NHXCH FE180/E90 4x1,5/1,5 RE
4	2 cables NHXCH FE180/ E90 4x50/25 RM
5	2 cables HDGs FE180/E90 4x1,0 RE
6	2 cables HDGs FE180/E90 4x4,0 RE
7	2 cables NHXCH FE180/E90 4x1,5/1,5 RE
8	2 cables NHXCH FE180/ E90 4x50/25 RM
9	2 cables HDGs FE180/E90 4x4,0 RE
10	2 cables HDGs FE180/E90 4x1,0 RE

x Conductor was turned off manually after permanent interruption / failure of other conductors in the cable

Power cables were tested by three-phase voltage supply 3 x 230/400V with bulbs 240V / 60 W. Circuit breakers with rating 3 A were used.

Measured time of tested specimens from S11 to S20

Specimen	Bulbs	Time to permanent failure / interruption [min:s]
S11	41-L1	no failure / interruption
	42-L2	no failure / interruption
	43-L3	no failure / interruption
	44-PEN	no failure / interruption
S12	45-L1	no failure / interruption
	46-L2	no failure / interruption
	47-L3	no failure / interruption
	48-PEN	no failure / interruption
S13	49-L1	no failure / interruption
	50-L2	no failure / interruption
	51-L3	no failure / interruption
	52-PEN	no failure / interruption
S14	53-L1	no failure / interruption
	54-L2	no failure / interruption
	55-L3	no failure / interruption
	56-PEN	no failure / interruption
S15	57-L1	x
	58-L2	6:36
	59-L3	6:36
	60-PEN	x
S16	61-L1	11:11
	62-L2	11:11
	63-L3	x
	64-PEN	x
S17	65-L1	x
	66-L2	x
	67-L3	11:29
	68-PEN	x
S18	69-L1	45:32
	70-L2	45:32
	71-L3	x
	72-PEN	x
S19	73-L1	88:56
	74-L2	88:56
	75-L3	88:56
	76-PEN	x
S20	77-L1	x
	78-L2	13:42
	79-L3	13:42
	80-PEN	x

Specimen No.	Cables
11	2 cables NHXCH FE180/E90 4x1,5/1,5 RE
12	2 cables NHXH FE180/ E90 4x1,5 RE
13	2 cables NHXCH FE180/ E90 4x50/25 RM
14	2 cables NHXH FE180/ E90 4x50 RM
15	2 cables HDGsekwf FE180/E90 4x1,0 RE
16	2 cables HDGsekwf FE180/ E90 4x4,0 RE
17	2 cables HLGs FE180/E90 4x1,0 RE
18	2 cables HDGs FE180/E90 4x1,0 RE
19	2 cables (N)HXH FE180/E90 4x1,5 RE
20	2 cables HDGsekwf FE180/E90 4x1,0 RE

x Conductor was turned off manually after permanent interruption / failure of other conductors in the cable

Power cables were tested by three-phase voltage supply 3 x 230/400V with bulbs 240V / 60 W. Circuit breakers with rating 3 A were used.

Measured time of tested specimens from S21 to S30

Specimen	Bulbs	Time to permanent failure / interruption [min:s]
S21	81-L1	x
	82-L2	x
	83-L3	17:09
	84-PEN	x
S22	85-L1	no failure / interruption
	86-L2	no failure / interruption
	87-L3	no failure / interruption
	88-PEN	no failure / interruption
S23	89-L1	no failure / interruption
	90-L2	no failure / interruption
	91-L3	no failure / interruption
	92-PEN	no failure / interruption
S24	93-L1	no failure / interruption
	94-L2	no failure / interruption
	95-L3	no failure / interruption
	96-PEN	no failure / interruption
S25	97-L1	no failure / interruption
	98-L2	no failure / interruption
	99-L3	no failure / interruption
	100-PEN	no failure / interruption
S26	101-L1	no failure / interruption
	102-L2	no failure / interruption
	103-L3	no failure / interruption
	104-PEN	no failure / interruption
S27	105-L1	73:40
	106-L2	x
	107-L3	x
	108-PEN	x
S28	109-L1	x
	110-L2	73:40
	111-L3	73:40
	112-PEN	x
S29	113-L1	13:11
	114-L2	13:11
	115-L3	13:11
	116-PEN	x
S30	117-L1	47:12
	118-L2	47:12
	119-L3	47:12
	120-PEN	x

Specimens No.	Cables
21	2 cables HDGsekwf FE180/ E90 4x4,0 RE
22	2 cables HDGs FE180/ E90 4x4,0 RE
23	2 cables HDGs FE180/E90 4x1,0 RE
24	2 cables NHXH FE180/E90 4x4,0 RE
25	2 cables HDGs FE180/E90 4x4,0 RE
26	2 cables HDGs FE180/E90 4x1,0 RE
27	2 cables HDGs FE180/E90 4x4,0 RE
28	2 cables HDGs FE180/E90 4x1,0 RE
29	2 cables HDGs FE180/E90 4x1,0 RE
30	2 cables HDGs FE180/E90 4x4,0 RE

x Conductor was turned off manually after permanent interruption / failure of other conductors in the cable

Power cables were tested by three-phase voltage supply 3 x 230/400V with bulbs 240V / 60 W.
Circuit breakers with rating 3 A were used.

Measured time of tested specimens from S31 to S40

Specimen	Bulbs	Time to permanent failure / interruption [min:s]
S31	121-L1	no failure / interruption
	122-L2	no failure / interruption
	123-L3	no failure / interruption
	124-PEN	no failure / interruption
S32	125-L1	no failure / interruption
	126-L2	no failure / interruption
	127-L3	no failure / interruption
	128-PEN	no failure / interruption
S33	129-L1	x
	130-L2	x
	131-L3	52:37
	132-PEN	x
S34	133-L1	no failure / interruption
	134-L2	no failure / interruption
	135-L3	no failure / interruption
	136-PEN	no failure / interruption
S35	137-L1	no failure / interruption
	138-L2	no failure / interruption
	139-L3	no failure / interruption
	140-PEN	no failure / interruption
S36	141-L1	no failure / interruption
	142-L2	no failure / interruption
	143-L3	no failure / interruption
	144-PEN	no failure / interruption
S37	145-L1	no failure / interruption
	146-L2	no failure / interruption
	147-L3	no failure / interruption
	148-PEN	no failure / interruption
S38	149-L1	no failure / interruption
	150-L2	no failure / interruption
	151-L3	no failure / interruption
	152-PEN	no failure / interruption
S39	153-L1	no failure / interruption
	154-L2	no failure / interruption
	155-L3	no failure / interruption
	156-PEN	no failure / interruption
S40	157-L1	no failure / interruption
	158-L2	no failure / interruption
	159-L3	no failure / interruption
	160-PEN	no failure / interruption

Specimens No.	Cables
31	2 cables NHXCH FE180/E90 4x1,5/1,5 RE
32	2 cables NHXCH FE180/E90 4x50/25 RM
33	2 cables HDGs FE180/E90 4x1,0 RE
34	2 cables HDGs FE180/E90 4x4,0 RE
35	2 cables (N)HXH FE180/E90 4x1,5 RE
36	cable (N)HXH FE180/E90 5x50 RM
37	cable (N)HXH FE180/E90 5x50 RM
38	2 cables NHXCH FE180/E90 4x1,5/1,5 RE
39	2 cables NHXH FE180/ E90 4x1,5 RE
40	cable NHXCH FE180/ E90 4x50/25 RM

x Conductor was turned off manually after permanent interruption / failure of other conductors in the cable

Power cables were tested by three-phase voltage supply 3 x 230/400V with bulbs 240V / 60 W. Circuit breakers with rating 3 A were used.

Measured time of tested specimens from S41 to S51

Specimen	Bulbs	Time to permanent failure / interruption [min:s]
S41	161-L1	no failure / interruption
	162-L2	no failure / interruption
	163-L3	no failure / interruption
	164-PEN	no failure / interruption
S42	165-L1	no failure / interruption
	166-L2	no failure / interruption
	167-L3	no failure / interruption
	168-PEN	no failure / interruption
S43	169-L1	no failure / interruption
	170-L2	no failure / interruption
	171-L3	no failure / interruption
	172-PEN	no failure / interruption
S44	173-L1	x
	174-L2	x
	175-L3	90:22
	176-PEN	x
S45	177-L1	no failure / interruption
	178-L2	no failure / interruption
	179-L3	no failure / interruption
	180-PEN	no failure / interruption
S46	181-L1	no failure / interruption
	182-L2	no failure / interruption
	183-L3	no failure / interruption
	184-PEN	no failure / interruption
S47	185-L1	no failure / interruption
	186-L2	no failure / interruption
	187-L3	no failure / interruption
	188-PEN	no failure / interruption
S48	189-L1	no failure / interruption
	190-L2	no failure / interruption
	191-L3	no failure / interruption
	192-PEN	no failure / interruption
S49	193-L1	no failure / interruption
	194-L2	no failure / interruption
	195-L3	no failure / interruption
	196-PEN	no failure / interruption
S50	197-L1	86:17
	198-L2	x
	199-L3	x
	200-PEN	x
S51	201-L1	no failure / interruption
	202-L2	no failure / interruption
	203-L3	no failure / interruption
	204-PEN	no failure / interruption

Specimens No.	Cables
41	cable NHXCH FE180/ E90 4x50/25 RM
42	cable NHXH FE180/ E90 4x50 RM
43	cable NHXH FE180/ E90 4x50 RM
44	2 cables NHXH FE180/E90 4x1,5 RE
45	cable NHXH FE180/E90 4x50 RM
46	cable NHXH FE180/E90 4x50 RM
47	2 cables NHXH FE180/E90 4x1,5 RE
48	cable NHXH FE180/E90 4x50 RM
49	cable NHXH FE180/E90 4x50 RM
50	2 cables HDGs FE180/E90 4x4,0 RE
51	2 cables HDGs FE180/E90 4x1,0 RE

- x Conductor was turned off manually after permanent interruption / failure of other conductors in the cable Power cables were tested by three-phase voltage supply 3 x 230/400V with bulbs 240V / 60 W. Circuit breakers with rating 3 A were used.

Measured time of tested specimens from S52 to S61

Specimen	Bulbs	Time to permanent failure / interruption [min:s]
S52A	209-L	no failure / interruption
	210-PEN	no failure / interruption
S52B	211-L	no failure / interruption
	212-PEN	no failure / interruption
S53A	213-L	no failure / interruption
	214-PEN	no failure / interruption
S53B	215-L	no failure / interruption
	216-PEN	no failure / interruption
S54A	217-L	no failure / interruption
	218-PEN	no failure / interruption
S54B	219-L	no failure / interruption
	220-PEN	no failure / interruption
S55A	221-L	no failure / interruption
	222-PEN	no failure / interruption
S55B	223-L	no failure / interruption
	224-PEN	no failure / interruption
S56A	225-L	no failure / interruption
	226-PEN	no failure / interruption
S56B	227-L	no failure / interruption
	228-PEN	no failure / interruption
S57	229-L	no failure / interruption
	230-PEN	no failure / interruption
	231-L	no failure / interruption
S58	232-PEN	no failure / interruption
	233-L	no failure / interruption
	234-PEN	no failure / interruption
	235-L	no failure / interruption
S59A	236-PEN	no failure / interruption
	237-L	no failure / interruption
S59B	238-PEN	no failure / interruption
	239-L	no failure / interruption
S60A	240-PEN	no failure / interruption
	241-L	no failure / interruption
S60B	242-PEN	no failure / interruption
	243-L	no failure / interruption
S61	244-PEN	no failure / interruption
	245-L	48:59
	246-PEN	x
	247-L	x
	248-PEN	x

Specimens No.	Cables
52	2 cables Securi Flame F 1x2x0,75
53	2 cables HTKSHekw FE180/90 1x2x0,8
54	2 cables HTKSHekw FE180/E90 1x2x0,8
55	2 cables HTKSHekw FE180/90 1x2x0,8
56	2 cables HTKSHekw FE180/90 1x2x0,8
57	cable JE-H(St)H.. RE FE180/ E90 2x2x 0.8
58	cable JE-H(St)H.. RE FE180/ E90 2x2x 0.8
59	2 cables HTKSHekw FE180/90 1x2x0,8
60	2 cables HTKSHekw FE180/E90 1x2x0,8
61	cable JE-H(St)H.. RE FE180/E90 2x2x 0.8

x Conductor was turned off manually after permanent interruption / failure of other conductors in the cable

Signal cables were tested by three-phase voltage supply 1 x 110V with LED diods 3V / 0,03W.
Circuit breakers with rating 3 A were used.

Measured time of tested specimens from S62 to S66

Specimen	Bulbs	Time to permanent failure / interruption [min:s]
S62	249-L	64:49
	250-PEN	x
	251-L	x
	252-PEN	x
S63A	253-L	no failure / interruption
	254-PEN	no failure / interruption
S63B	255-L	no failure / interruption
	256-PEN	no failure / interruption
S64	257-L	no failure / interruption
	258-PEN	no failure / interruption
	259-L	no failure / interruption
	260-PEN	no failure / interruption
S65	261-L	no failure / interruption
	262-PEN	no failure / interruption
	263-L	no failure / interruption
	264-PEN	no failure / interruption
S66A	265-L	no failure / interruption
	266-PEN	no failure / interruption
S66B	267-L	no failure / interruption
	268-PEN	no failure / interruption

Specimens No.	Cables
62	cable JE-H(St)H.. RE FE180/E90 2x2x 0.8
63	2 cables HTKSHekw FE180/E90 1x2x0,8
64	cable JE-H(St)H.. RE FE180/E90 2x2x 0.8
65	cable JE-H(St)H.. RE FE180/E90 2x2x 0.8
66	2 cables HTKSHekw FE180/90 1x2x0,8

x Conductor was turned off manually after permanent interruption / failure of other conductors in the cable

Signal cables were tested by three-phase voltage supply 1 x 110V with LED diods 3V / 0,03W.

Circuit breakers with rating 3 A were used.

PHOTOS



Photo taken before the test



Photo taken before the test
suspension track [9], [1]



Photo taken before the test –
suspension track [2]

PHOTOS



Photo taken before the test - suspension track [10]



Photo taken after the test - suspension track [11], [3]



Photo taken after the test - suspension track [4]

PHOTOS



Photo taken after the test – suspension track [12], [13] , [5]



Photo taken before the test – suspension track [6]



Photo taken before the test – suspension track [14]

PHOTOS



Photo taken before the test – suspension track from [7]



Photo taken before the test – suspension track from [8]



Photo taken after the test

PHOTOS



Photo taken after the test



Photo taken after the test



Photo taken after the test

PHOTOS



Photo taken after the test



Photo taken after the test



Photo taken after the test

PHOTOS



Photo taken after the test



Photo taken after the test



Photo taken after the test

(N)HXH E90

FIRE RESISTANT HALOGEN FREE POWER CABLES

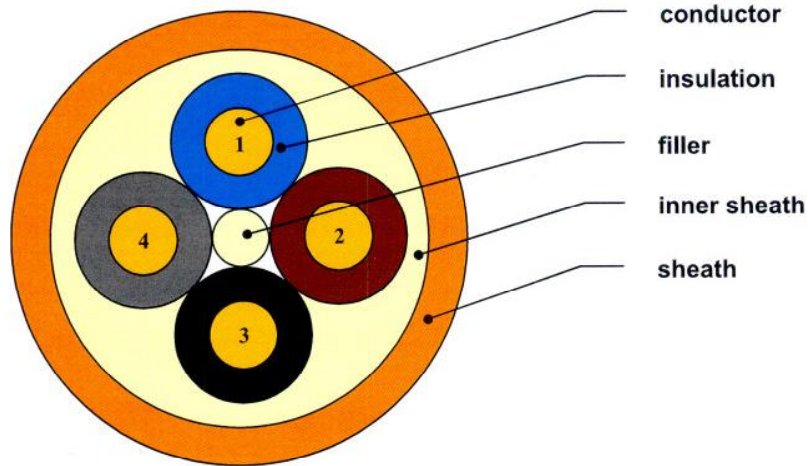

APPLICATIONS

Safety cables are used in all locations where a special protection against fire and fire damage is necessary for human life and equipment and where strict safety regulations have to be met and where large emergency running time is necessary. They may be used indoor and outdoor, but not directly in earth and water. They are considered as protectively insulated.

CONSTRUCTION



conductor - bare copper, solid or stranded acc. to DIN VDE 0295

insulation - cross-linked halogen free ceramic forming polymer compound acc. to DIN VDE 0266

filler - flame resistant, halogen free polymer compound

inner sheath - flame resistant, halogen free polymer compound

sheath - flame resistant, halogen free polymer compound acc. to DIN VDE 0276-604

 FIRES s.r.o. POŽIARNA ODOLNOSŤ FIRE RESISTANCE	Dátum/Date 16.09.2010
	 Podpis/Signature
Dokument č. Document No. <i>FIRES-FR-121-10-NWE</i>	
Príloha č./Appendix No. <i>14</i>	

(N)HXH E90



CHARACTERISTICS

Conductor cross-section	
Number of conductors	Nominal conductor cross-section
n	mm ²
1 + 5	1,5 + 240
7 + 10	1,5 + 10
10 + 48	1,5 + 2,5

Operating voltage 0,6/1kV
Voltage test 4000 V, 50 Hz
Insulation resistivity at 90°C,
minimum 10^{12}

Operating temperature range
during operation -25°C up to +90°C
during installation -5°C up to +50°C
Minimum bending radius
15 x D single core
12 x D multi core
D = outer diameter

Cable combustibility
Fire resistance E90
Combustibility tests PN-EN 50226:2006, IEC 60332-3
Reference standards DIN VDE 0266

 FIRES S.I.O. POŽIARNA ODOLNOSŤ FIRE RESISTANCE	Dátum/Date 16. 09. 2010
	 Podpis/Signature
Dokument č. Document No.	FIRES-FR-121-10-10WE
Príloha č./Appendix No.	18

NHXH E90

FIRE RESISTANT HALOGEN FREE POWER CABLES

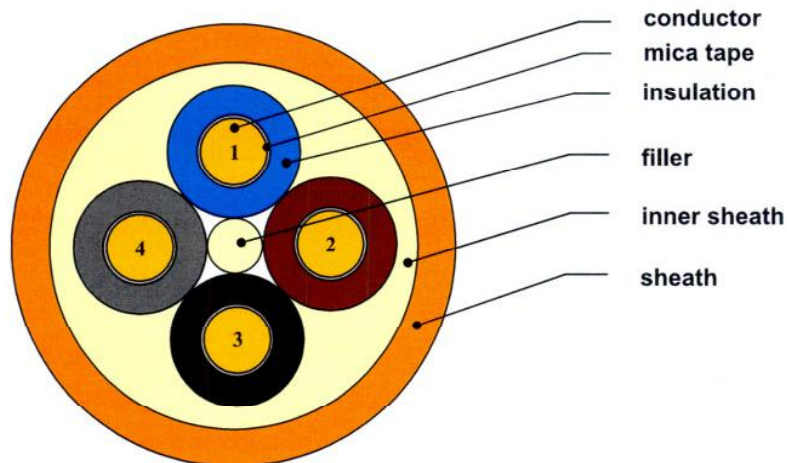

APPLICATIONS

Safety cables are used in all locations where a special protection against fire and fire damage is necessary for human life and equipment and where strict safety regulations have to be met and where large emergency running time is necessary. They may be used indoor and outdoor, but not directly in earth and water. They are considered as protectively insulated.

CONSTRUCTION



conductor - bare copper, solid or stranded acc. to DIN VDE 0295

insulation - mica tape and cross-linked halogen free forming polymer compound acc. to DIN VDE 0266

filler - flame resistant, halogen free polymer compound

inner sheath - flame resistant, halogen free polymer compound

sheath - flame resistant, halogen free polymer compound acc. to DIN VDE 0276-604

	Dátum/Date 16. 09. 2010
	 Podpis/Signature
	Dokument č. Document No. FIRES-FR-191-10-NWE
Príloha č./Appendix No. 19	

NHXH E90

CHARACTERISTICS

Conductor cross-section	
Number of conductors	Nominal conductor cross-section
n	mm ²
1 ÷ 5	1,5 ÷ 300
7 ÷ 10	1,5 ÷ 10
10 ÷ 48	1,5 ÷ 2,5

Operating voltage 0,6/1kV
 Voltage test 4000 V, 50 Hz
 Insulation resistivity at 90°C, minimum 10¹²

Operating temperature range during operation during installation -25°C up to +90°C
 -5°C up to +50°C
 Minimum bending radius
 15 x D single core
 12 x D multi core
 D = outer diameter

Cable combustibility
 Fire resistance E90
 Combustibility tests PN-EN 50226:2006, IEC 60332-3
 Reference standards DIN VDE 0266

 FIRES s.r.o. POŽIARNA ODOLNOSŤ FIRE RESISTANCE	Dátum/Date 16.09.2010
	Podpis/Signature 
Dokument č. / Document No. FIRES-FR-191-10-ANWE	
Príloha č./Appendix No. 20	

NHXCH E90

FIRE RESISTANT HALOGEN FREE POWER CABLES

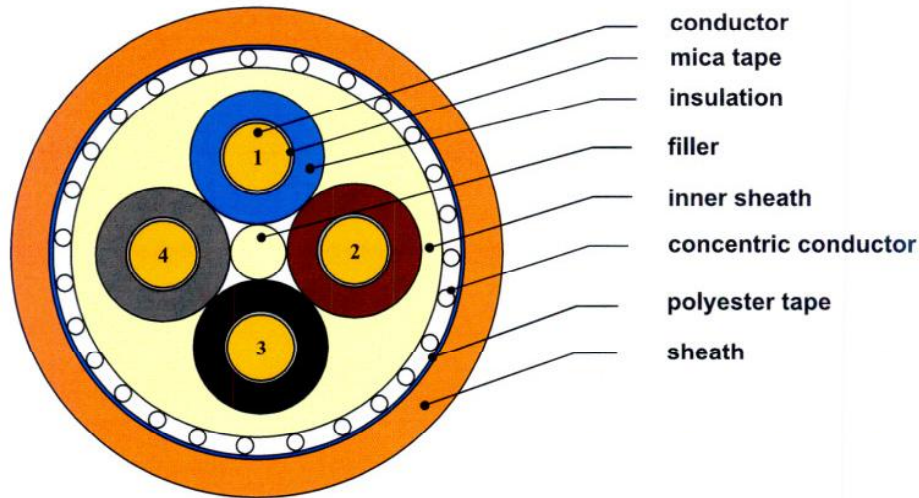

APPLICATIONS

Safety cables are used in all locations where a special protection against fire and fire damage is necessary for human life and equipment and where strict safety regulations have to be met and where large emergency running time is necessary. They may be used indoor and outdoor, but not directly in earth and water. They are considered as protectively insulated.

CONSTRUCTION

conductor - bare copper, solid or stranded acc. to DIN VDE 0295

insulation - mica tape and cross-linked halogen free forming polymer compound acc. to DIN VDE 0266



filler - flame resistant, halogen free polymer compound

inner sheath - flame resistant, halogen free polymer compound

concentric conductor - formed by bare copper wires with counter copper tape

polyester tape

sheath - flame resistant, halogen free polymer compound acc. to DIN VDE 0276-604



 FIRES s.r.o. POŽIARNA ODOLNOSŤ FIRE RESISTANCE	Dátum/Date 16. 09. 2010
	 Podpis/Signature
Dokument č. Document No.	FIRES-FR-191-10-ANNE
Príloha č./Appendix No.	21

NHXCH E90

CHARACTERISTICS

Conductor cross-section	
Number of conductors	Nominal conductor cross-section
n	mm ²
1 + 4	1,5/1,5 + 240/120
7	1,5/1,5 + 4/4
10 + 30	1,5/2,5 + 2,5/10

Operating voltage	0,6/1 kV	Operating temperature range	
Voltage test	4000 V, 50 Hz	during operation	-25°C up to +90°C
Insulation resistivity at 90°C, minimum	10 ¹²	during installation	-5°C up to +50°C
		Minimum bending radius	15 x D single core 12 x D multi core D = outer diameter
		Cable combustibility	
		Fire resistance	E90
		Combustibility tests	PN-EN 50226:2006, IEC 60332-3
		Reference standards	DIN VDE 0266

 FIRES S.T.O. POŽIARNA ODOLNOSŤ FIRE RESISTANCE	Dátum/Date 16.09.2010
	 Podpis/Signature
	Dokument č. Document No. FIRES-FR-111-10-PNJE
Príloha č./Appendix No. 22	

HDGs FE180/E90

FIRE RESISTANT HALOGEN FREE POWER CABLE

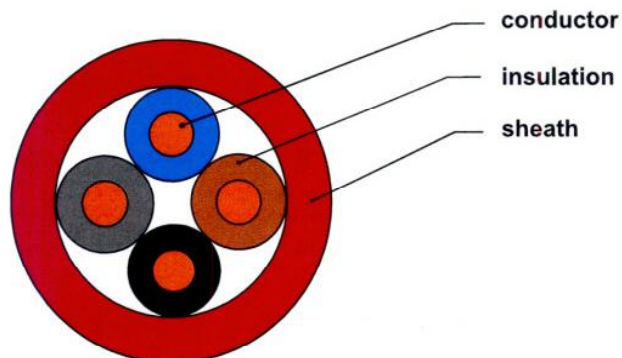

APPLICATIONS



Halogen-free fire resistant cables are designed for installation in places where it is necessary to ensure operation of devices under fire conditions. There are recommended for emergency lighting installations, smoke extraction systems, alarm systems, signalling systems, sound warning and control systems, fire alarm signaling and automation and other safety ensuring circuits.

CONSTRUCTION

conductor - bare copper, solid acc. to PN-EN 60228:2005

insulation - cross-linked halogen free ceramic forming polymer compound

sheath - flame resistant, halogen free polymer compound

	Dátum/Date 16.09.2010
	 Podpis/Signature
	Dokument č. Document No. <i>FIRES-FR-141-10-11NE</i>
Príloha č./Appendix No. <i>23</i>	

HDGs FE180/E90

CHARACTERISTICS

Conductor cross-section	
Number of conductors	Nominal conductor cross-section
n	mm ²
2 + 5	1 + 4
6 + 37	1 + 2,5

Operating voltage 300/500 V
Voltage test core/core 2000 V, 50 Hz
core/screen 2000 V, 50 Hz

Insulation resistivity at 90°C, minimum 10¹¹

Operating temperature range during operation -25°C up to +70°C
during installation -10°C up to +50°C
Minimum bending radius 10 x D single core
D = outer diameter

Cable combustibility
Fire resistance E90
Combustibility tests PN-EN 50200, PN-EN 50226:2006
IEC 60332-3
Reference standards ZN-CB-03-2002

 FIRES S.T.O. POŽIARNA ODOLNOSŤ FIRE RESISTANCE	Dátum/Date 16.09.2010
	 Podpis/Signature
Dokument č. Document No.	FIRES-FR-191-10-AWJE
Príloha č./Appendix No.	24

HDGsekwf FE180/E90

FIRE RESISTANT HALOGEN FREE POWER CABLE

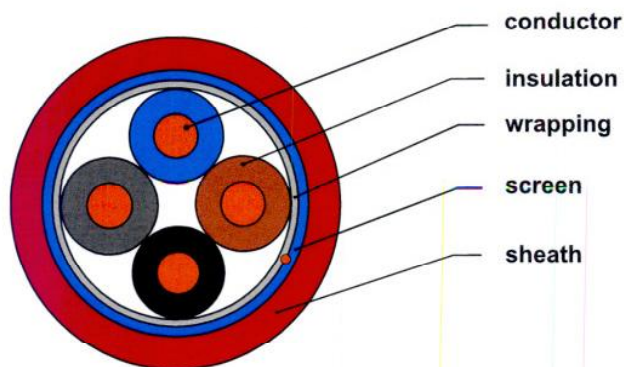

APPLICATIONS

Halogen-free fire resistant cables are designed for installation in places where it is necessary to ensure operation of devices under fire conditions. There are recommended for emergency lighting installations, smoke extraction systems, alarm systems, signalling systems, sound warning and control systems, fire alarm signaling and automation and other safety ensuring circuits.

CONSTRUCTION



conductor - bare copper, solid acc. to PN-EN 60228:2005

insulation - cross-linked halogen free ceramic forming polymer compound

wrapping - polyester tape

screen - static screen of plastic coated metal foil with tinned copper drain wire

sheath - flame resistant, halogen free polymer compound

 FIRES S.T.O. POŽIARNA ODOLNOST FIRE RESISTANCE	Dátum/Date 16.09.2010
	 Podpis/Signature
Dokument č. Document No.	FIRES-FR-144-10-AUNE
Príloha č./Appendix No.	25

HDGsekwf FE180/E90



CHARACTERISTICS

Conductor cross-section	
Number of conductors	Nominal conductor cross-section
n	mm ²
2 + 5	1 + 4
6 + 37	1 + 2,5

Operating voltage 300/500 V
Voltage test core/core 2000 V, 50 Hz
core/screen 2000 V, 50 Hz
Insulation resistivity at 90°C, minimum 10¹¹

Operating temperature range during operation -25°C up to +70°C
during installation -10°C up to +50°C
Minimum bending radius 10 x D single core
D = outer diameter

Cable combustibility
Fire resistance E90
Combustibility tests PN-EN 50200, PN-EN 50226:2006
IEC 60332-3
Reference standards ZN-CB-03-2002

 FIRES S.T.O. POŽIARNA ODOLNOSŤ FIRE RESISTANCE	Dátum/Date 11.09.2010
	 Podpis/Signature
	Dokument č. / Document No. FIRES-FR-141-10-ANNE Príloha č./Appendix No. 26

HLGs FE180/E90

FIRE RESISTANT HALOGEN FREE POWER CABLE

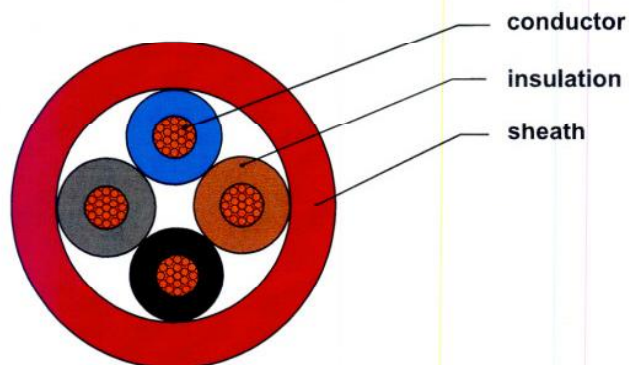

APPLICATIONS

Halogen-free fire resistant cables are designed for installation in places where it is necessary to ensure operation of devices under fire conditions. There are recommended for emergency lighting installations, smoke extraction systems, alarm systems, signalling systems, sound warning and control systems, fire alarm signaling and automation and other safety ensuring circuits.

CONSTRUCTION

conductor - multistranded copper conductor, class 5 acc. to: PN-EN 60228:2005

insulation - cross-linked halogen free ceramic forming polymer compound

sheath - flame resistant, halogen free polymer compound

 FIRES S.R.O. POŽIARNA ODOLNOST FIRE RESISTANCE	Dátum/Date <i>16.04.2010</i>
	<i>[Signature]</i> Podpis/Signature
Dokument č. Document No. <i>FIRES-FR-181-10-ANNE</i>	
Priloha č./Appendix No. <i>29</i>	

HLGs FE180/E90

CHARACTERISTICS

Conductor cross-section	
Number of conductors	Nominal conductor cross-section
n	mm ²
2 + 5	1 + 4
6 + 37	1 + 2,5

Operating voltage 300/500 V
 Voltage test core/core 2000 V, 50 Hz
 core/screen 2000 V, 50 Hz
 Insulation resistivity at 90°C, minimum 10¹¹

Operating temperature range during operation -25°C up to +70°C
 during installation -10°C up to +50°C
 Minimum bending radius 6 x D single core
 D = outer diameter

Cable combustibility
 Fire resistance E90
 Combustibility tests PN-EN 50200, PN-EN 50226:2006
 IEC 60332-3
 Reference standards ZN-CB-03-2002

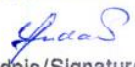
 FIRES S.R.O. POŽIARNA ODOLNOSŤ FIRE RESISTANCE	Dátum/Date 16.09.2010
	Podpis/Signature 
Dokument č. / Document No. <i>FIRES-FR-141-10-ANNE</i>	
Príloha č./Appendix No. <i>28</i>	

HTKSH(ekw) FE180/E90

FIRE RESISTANT HALOGEN FREE ELECTRONIC AND TELECOMMUNICATIONS CABLE

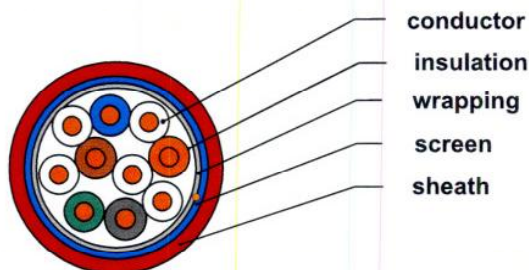

APPLICATIONS

Safety installations cables are used for the transmission signals and measuring data in control circuits, in locations where a particular protection against fire and fire damage for human life and equipment is necessary.

Installation cables are not admissible for power installation purposes and direct burial.

CONSTRUCTION

conductor - bare copper, solid acc. to PN-EN 60228:2005

insulation - mica tape and halogen free forming polymer compound

wrapping - polyester tape

screen - static screen of plastic coated metal foil with a solid, tinned drain wire

sheath - flame resistant, halogen free polymer compound

 FIRES S.I.O. POŽIARNA ODOLNOSŤ FIRE RESISTANCE	Dátum/Date 16.09.2010
	 Podpis/Signature
Dokument č. Document No. <i>FIRES-FR-180-E90-ANE</i>	
Príloha č./Appendix No. <i>24</i>	

HTKSH(ekw) FE180/E90

CHARACTERISTICS

Conductor cross-section	
Number of conductors	Nominal conductor diameter
n	mm
1 x 2 x 20 x 2 x	0,8
1 x 2 x 10 x 2 x	1,0
1 x 2 x 10 x 2 x	1,4
1 x 2 x 10 x 2 x	1,8
1 x 2 x 10 x 2 x	2,3

Operating voltage 225V
 Voltage test core/core 1500 V, 50 Hz
 core/screen 1500 V, 50 Hz
 Insulation resistivity at 90°C, minimum 10¹¹

Operating temperature range during operation during installation -25°C up to +70°C
 -5°C up to +50°C
 Minimum bending radius 10 x D single core
 D = outer diameter

Cable combustibility E90
 Fire resistance PN-EN 50200, PN-EN 50226:2006
 Combustibility tests IEC 60332-3
 Reference standards ZN-CB-25-2005

 FIRES S.I.O. POŽIARNA ODOLNOST FIRE RESISTANCE	Dátum/Date 16.09.2010
	Podpis/Signature 
Dokument č. / Document No. FIRES-FR-111-10-110E	
Príloha č./Appendix No. 30	

JE-H(St)H MIKA E90

FIRE RESISTANT HALOGEN FREE ELECTRONIC AND TELECOMMUNICATIONS CABLE

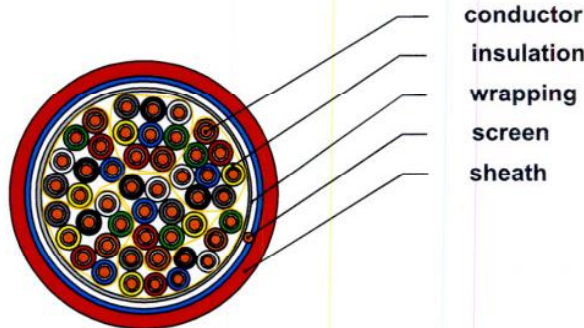

APPLICATIONS

Safety installations cables are used for the transmission of signals and measuring data in control circuits, in locations where a particular protection against fire and fire damage for human life and equipment is necessary.

Installation cables are not admissible for power installation purposes and direct burial.

CONSTRUCTION



conductor - bare copper, solid acc. to DIN VDE 0295

insulation - mica tape and cross-linked halogen free forming polymer compound acc. to DIN VDE 0207-23

wrapping - polyester and glass-fibre tape

screen - static screen of plastic coated metal foil with a solid, tinned drain wire

sheath - flame resistant, halogen free polymer compound acc. to DIN VDE 0207-5

 FIRES S.r.o. POŽIARNA ODOLNOSŤ FIRE RESISTANCE	Dátum/Date 16.09.2010
	 Podpis/Signature
Dokument č. Document No.	FIRES-FR-184-10-ADNE
Príloha č./Appendix No.	31

JE-H(St)H MIKA E90

CHARACTERISTICS

Conductor diameter	
Number of conductors	Nominal conductor diameter
n	mm
1 x 2 x 80 x 2 x	0,8
1 x 2 x 80 x 2 x	1,0

Operating voltage 225V
 Voltage test core/core 500 V, 50 Hz
 core/screen 2000 V, 50 Hz
 Insulation resistivity at 90°C, minimum 10^{12}

Operating temperature range during operation during installation -25°C up to +80°C
 -5°C up to +50°C
 Minimum bending radius 8 x D single core
 D = outer diameter

Cable combustibility
 Fire resistance E90
 Combustibility tests PN-EN 50226:2006, IEC 60332-3
 Reference standards DIN VDE 0815

 FIRES s.r.o. POŽIARNA ODOLNOSŤ FIRE RESISTANCE	Dátum/Date 16. 09. 2010
	 Podpis/Signature
Dokument č. / Document No. <i>FIRES-FR-141-10-ANNE</i>	
Príloha č./Appendix No. <i>32</i>	

Securi-flame F FE180/E90

FIRE RESISTANT HALOGEN FREE SIGNAL CABLE

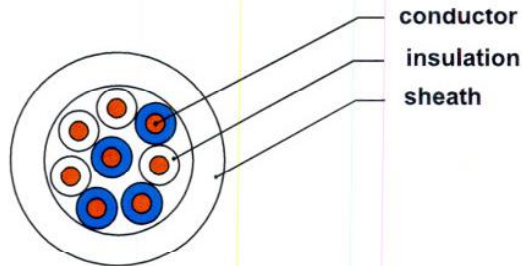

APPLICATIONS

Halogen-free fire resistant cables are designed for installation in places where it is necessary to ensure operation of devices under fire conditions. There are recommended for emergency lighting installations, smoke extraction systems, alarm systems, signalling systems, sound warning and control systems, fire alarm signaling and automation and other safety ensuring circuits.

CONSTRUCTION

conductor - bare copper, stranded class 2 acc. to EN 60228

insulation - cross-linked halogen free ceramic forming polymer compound

sheath - flame resistant, halogen free polymer compound

 FIRES S.r.o. POŽIARNA ODOLNOSŤ FIRE RESISTANCE	Dátum/Date <i>16.09.2010</i>
	<i>[Signature]</i> Podpis/Signature
Dokument č. Document No. <i>FIRES-FR-180-E90</i>	
Príloha č./Appendix No. <i>33</i>	

Securi-flame F FE180/E90

CHARACTERISTICS

Conductor diameter	
Number of conductors	Nominal conductor cross-section
n	mm ²
1 x 2 x	0,75
8 x 2 x	

Operating voltage	300/500V	Operating temperature range	
Voltage test		during operation	-40°C up to +80°C
core/core	2500 V, 50 Hz	during installation	-5°C up to +50°C
core/screen	2500 V, 50 Hz	Minimum bending radius	6 x D single core D = outer diameter
Insulation resistivity at 90°C, minimum	10 ¹²	Cable combustibility	
		Fire resistance	E90
		Combustibility tests	EN 50200, EN 50226:2006 IEC 60332-3
		Reference standards	Based on ZN-CB-25:2005

 FIRES S.R.O. POŽIARNA ODOLNOSŤ FIRE RESISTANCE	Dátum/Date <i>16.09.2010</i>
	Podpis/Signature <i>[Signature]</i>
Dokument č. Document No. <i>FIRES-FR-191-10-ANNE</i>	
Príloha č./Appendix No. <i>39</i>	

Uchwyty UK01 + Szczepel SDOP 800
Kolek SRO M6x30
Mocowanie co 0,6m

Objeina OZO
Kolek SBO M5x60
Mocowanie co 0,6m

Uchwyty UDF
Kolek KWBO 6x35
Mocowanie co 0,6m

Objeina OZSO
Kolek KWBO 6x35
Mocowanie co 0,6m

Uchwyty UEF ...
Kolek KWBO 6x35
Mocowanie co 0,6m

Uchwyty UDF x2
Kolek GSD M6x40
Mocowanie co 0,6m

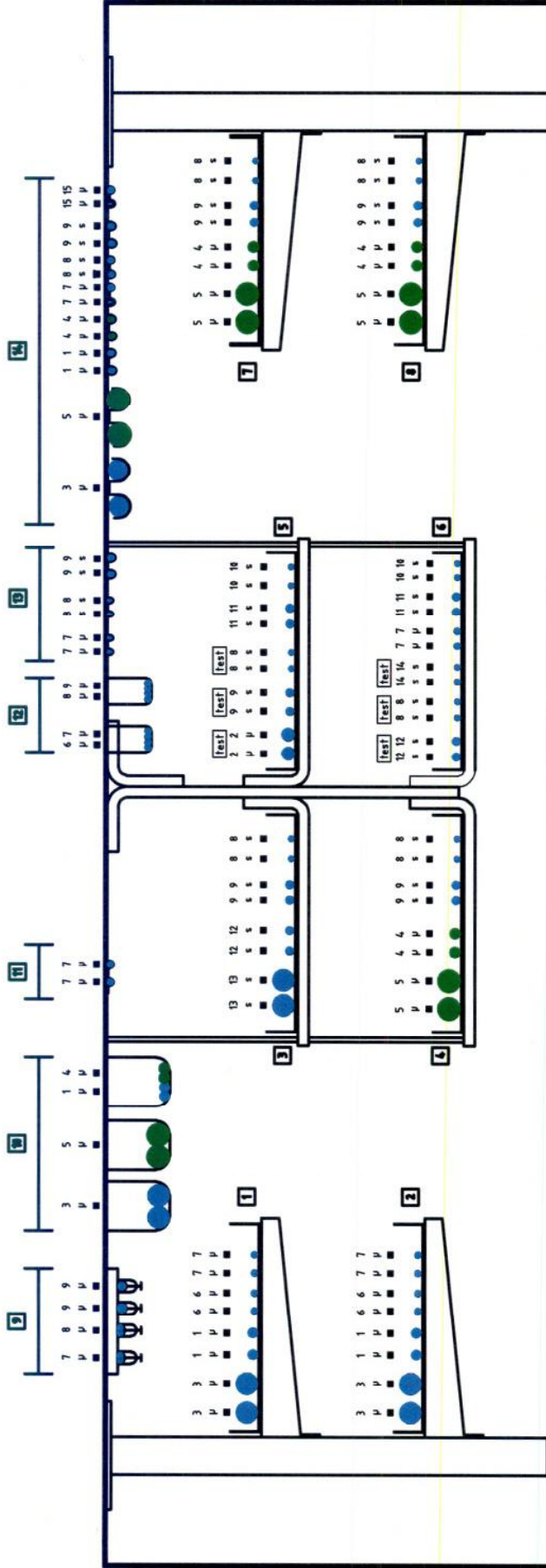

Korytko kablowe KCOP 400H60/3
Wspornik WPCE0700, Wysięgnik WMC0400
Tuleja stalowa PSRO M10x80
Mocowanie co 1,5m, Obciążenie 10 kg/m

Drabinka kablowa DUOP400H60/3
Wspornik WPCE0700, Wysięgnik WMC0400
Tuleja stalowa PSRO M10x80
Mocowanie co 1,5m, Obciążenie 20 kg/m

Korytko kablowe KCOP 400H60/3
Wysięgnik WFL0 600, Wysięgnik WFL0 400
Preł PGM 10/..., Tuleja stalowa TRSO M10x40
Mocowanie co 1,5m, Obciążenie 20 kg/m

Drabinka kablowa DGOP400H60/3
Wysięgnik WFL0 600, Wysięgnik WFL0 400
Preł PGM 10/..., Tuleja stalowa TRSO M10x40
Mocowanie co 1,5m, Obciążenie 20 kg/m

Korytko kablowe KCOP 400H60/3
Wysięgnik WFL0 600, Wysięgnik WFL0 400
Preł PGM 10/..., Tuleja stalowa TRSO M10x40
Mocowanie co 1,5m, Obciążenie 21 kg/m

Drabinka kablowa DGOP400H60/3
Wysięgnik WFL0 600, Wysięgnik WFL0 400
Preł PGM 10/..., Tuleja stalowa TRSO M10x40
Mocowanie co 1,5m, Obciążenie 21 kg/m

Korytko kablowe KCOP 400H60/3
Wspornik WPCE0700, Wysięgnik WMC0400
Tuleja stalowa PSRO M10x80
Mocowanie co 1,5m, Obciążenie 10 kg/m

Drabinka kablowa DUOP400H60/3
Wspornik WPCE0700, Wysięgnik WMC0400
Tuleja stalowa PSRO M10x80
Mocowanie co 1,5m, Obciążenie 20 kg/m



Rozmieszczenie próbek w piecu
Badanie kabli Bitner z osprzetem Baks
Batizovce 17.09.2010

FIRIS S.T.O.
POŻIARNA ODOLNOST
FIRE RESISTANCE

Dokument č. FIRES-FR-191-10-ANU
Document No.

Dátum/Date
16.09.2010

Podpis/Signature
[Signature]

Priloha č./Appendix No.
55

Badanie 13-17.09.2010

3000

9 10 11 12 13

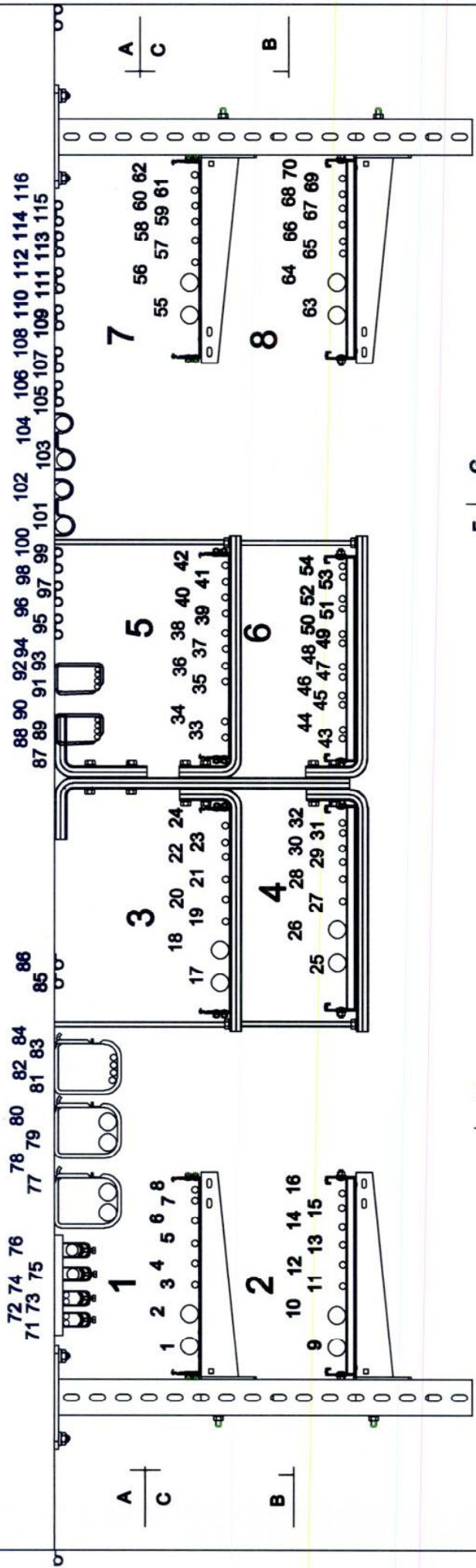

F | G

E | D

	Datum/Date <i>16.09.2010</i>
Podpis/Signature <i>[Signature]</i>	
Dokument č. / Document No. <i>FIRES-FR-M-10-AWE</i>	
Priloha č./Appendix No. <i>36</i>	

Badanie trasy kablowej BAKS - BITNER
Badanie w FIRES Słowacja Data 16.09.2010

Nr	Nr FIRES	Czas	Symbol kaba (napięcie)	Pozycja	Konstrukcja mocowania, odległość, obciążenie
1	49		NHXH FE180/E90 4x50 RM 0,6/1kV	1	Korytko kablowe KCOP 400H60/... B-400 1.5 m /10kg/m / grubość blachy 1,5 mm Mocowanie : Wspornik WPCEO 800, Wysięgnik WMCO 400 , do betonu za pomocą tulei stalowej PSRO M10x 80
2	48		NHXH FE180/E90 4x50 RM 0,6/1kV		
3	47		NHXH FE180/E90 4x1,5 RE 0,6/1kV		
4			NHXH FE180/E90 4x1,5 RE 0,6/1kV		
5	65		JE-H(St)H.. RE FE180/E90 2x2x 0.8		
6	64		JE-H(St)H.. RE FE180/E90 2x2x 0.8		
7	63		HTKSHekw FE180/E90 1x2x0,8		
8			HTKSHekw FE180/E90 1x2x0,8		
9	46		NHXH FE180/E90 4x50 RM 0,6/1kV	2	Drabina kablowa DUOP400H60/... B-400 1.5 m /20kg/m / grubość blachy 1,5 mm Mocowanie : Wspornik WPCEO 800, Wysięgnik WMCO 400 , do betonu za pomocą tulei stalowej PSRO M10x 80
10	45		NHXH FE180/E90 4x50 RM 0,6/1kV		
11	44		NHXH FE180/E90 4x1,5 RE 0,6/1kV		
12			NHXH FE180/E90 4x1,5 RE 0,6/1kV		
13	62		JE-H(St)H.. RE FE180/E90 2x2x 0.8		
14	61		JE-H(St)H.. RE FE180/E90 2x2x 0.8		
15	60		HTKSHekw FE180/E90 1x2x0,8		
16			HTKSHekw FE180/E90 1x2x0,8		
17	37		(N)HXH FE180/E90 5x50 RM 0,6/1kV	3	Korytko kablowe KCOP 400H60/... B-400 1.5 m /10kg/m / grubość blachy 1,5 mm Mocowanie : Wysięgnik WFLO 600, Wysięgnik WFLO 400 , pręt gwintowany PGM10/..., do betonu za pomocą tulei stalowej TRSO M10x40
18	36		(N)HXH FE180/E90 5x50 RM 0,6/1kV		
19	35		(N)HXH FE180/E90 4x1,5 RE 0,6/1kV		
20			(N)HXH FE180/E90 4x1,5 RE 0,6/1kV		
21	34		HDGs FE180/E90 4x4,0 RE 300/500V		
22			HDGs FE180/E90 4x4,0 RE 300/500V		
23	33		HDGs FE180/E90 4x1,0 RE 300/500V		
24			HDGs FE180/E90 4x1,0 RE 300/500V		
25	32		NHXCH FE180/E90 4x50/25 RM 0,6/1kV	4	Drabinka kablowa DUOP 400H60/... B-400 1.5 m /20kg/m / grubość blachy 1,5 mm Mocowanie : Wysięgnik WFLO 600, Wysięgnik WFLO 400 , pręt gwintowany PGM10/..., do betonu za pomocą tulei stalowej TRSO M10x 40
26			NHXCH FE180/E90 4x50/25 RM 0,6/1kV		
27	31		NHXCH FE180/E90 4x1,5/1,5 RE 0,6/1kV		
28			NHXCH FE180/E90 4x1,5/1,5 RE 0,6/1kV		
29	30		HDGs FE180/E90 4x4,0 RE 300/500V		
30			HDGs FE180/E90 4x4,0 RE 300/500V		
31	29		HDGs FE180/E90 4x1,0 RE 300/500V		
32			HDGs FE180/E90 4x1,0 RE 300/500V		
33	24		NHXH FE180/E90 4x4,0 RE 0,6/1kV	5	Korytko kablowe KCOP 400H60/... B-400 1.5 m /10kg/m / grubość blachy 1,5 mm Mocowanie : Wysięgnik WFLO 600, Wysięgnik WFLO400 , pręt gwintowany PGM10/..., do betonu za pomocą tulei stalowej TRSO M10x40
34			NHXH FE180/E90 4x4,0 RE 0,6/1kV		
35	23		HDGsekwf FE180/E90 4x1,0 RE 300/500V		
36			HDGsekwf FE180/E90 4x1,0 RE 300/500V		
37	22		HDGsekwf FE180/ E90 4x4,0 RE 300/500V		
38			HDGsekwf FE180/ E90 4x4,0 RE 300/500V		
39	21		HDGsekwf FE180/ E90 4x4,0 RE 300/500V		
40			HDGsekwf FE180/ E90 4x4,0 RE 300/500V		
41	20		HDGsekwf FE180/E90 4x1,0 RE 300/500V		
42			HDGsekwf FE180/E90 4x1,0 RE 300/500V		

 POZIARNA ODOLNOSĆ FIRE RESISTANCE	Dátum/Date 16. 09. 2010
	Podpis/Signature <i>Judaš</i>
Dokument č. / Document No. <i>FIRES-FR-111-10-AWJE</i>	
Príloha č./Appendix No. <i>34</i>	

Nr	Nr FIRES	Czas	Symbol kaba (napięcie)	Pozycja	Konstrukcja mocowania, odległość, obciążenie		
43	19		(N)HXH FE180/E90 4x1,5 RE 0,6/1kV	6	Drabinka kablowa DUOP 400H60/... B-400 1.5 m /20kg/m / grubość blachy 1,5 mm Mocowanie : Wysięgnik WFLO 600, Wysięgnik WFLO400 , pręt gwintowany PGM10/..., do betonu za pomocą tulei stalowej TRSO M10x 40		
44			(N)HXH FE180/E90 4x1,5 RE 0,6/1kV				
45	18		HDGs FE180/E90 4x1,0 RE 300/500V				
46			HDGs FE180/E90 4x1,0 RE 300/500V				
47	17		HLGs FE180/E90 4x1,0 RE 300/500V				
48			HLGs FE180/E90 4x1,0 RE 300/500V				
49	54A		HTKSHekw FE180/E90 1x2x0,8				
50	54B		HTKSHekw FE180/E90 1x2x0,8				
51	16		HDGsekwf FE180/ E90 4x4,0 RE 300/500V				
52			HDGsekwf FE180/ E90 4x4,0 RE 300/500V				
53	15		HDGsekwf FE180/E90 4x1,0 RE 300/500V				
54			HDGsekwf FE180/E90 4x1,0 RE 300/500V				
55	8		NHXCH FE180/ E90 4x50/25 RM 0,6/1kV	7	Korytko kablowe KCOP 400H60/... B-400 1.5 m /10kg/m / grubość blachy 1,5 mm Mocowanie : Wspornik WPCEO 800, Wysięgnik WMCO 400 , do betonu za pomocą tulei stalowej PSRO M10x 80		
56			NHXCH FE180/ E90 4x50/25 RM 0,6/1kV				
57	7		NHXCH FE180/E90 4x1,5/1,5 RE 0,6/1kV				
58			NHXCH FE180/E90 4x1,5/1,5 RE 0,6/1kV				
59	6		HDGs FE180/E90 4x4,0 RE 300/500V				
60			HDGs FE180/E90 4x4,0 RE 300/500V				
61	5		HDGs FE180/E90 4x1,0 RE 300/500V				
62			HDGs FE180/E90 4x1,0 RE 300/500V				
63	4		NHXCH FE180/ E90 4x50/25 RM 0,6/1kV			8	Drabina kablowa DUOP400H60/... B-400 1.5 m /20kg/m / grubość blachy 1,5 mm Mocowanie : Wspornik WPCEO 800, Wysięgnik WMCO 400 , do betonu za pomocą tulei stalowej PSRO M10x 80
64			NHXCH FE180/ E90 4x50/25 RM 0,6/1kV				
65	3		NHXCH FE180/E90 4x1,5/1,5 RE 0,6/1kV				
66			NHXCH FE180/E90 4x1,5/1,5 RE 0,6/1kV				
67	2		HDGs FE180/E90 4x4,0 RE 300/500V				
68			HDGs FE180/E90 4x4,0 RE 300/500V				
69	1		HDGs FE180/E90 4x1,0 RE 300/500V				
70			HDGs FE180/E90 4x1,0 RE 300/500V				
71	66A		HTKSHekw FE180/90 1x2x0,8	9	Uchwyt kablowy UKO1 + Szczelbel SDOP 200 Mocowanie do betonu co 600 mm za pomocą śruby rozporowej SRO M6x30		
72	66B		HTKSHekw FE180/90 1x2x0,8				
73	51		HDGs FE180/E90 4x1,0 RE 300/500V				
74			HDGs FE180/E90 4x1,0 RE 300/500V				
75	50		HDGs FE180/E90 4x4,0 RE 300/500V				
76			HDGs FE180/E90 4x4,0 RE 300/500V				
77	43		NHXH FE180/ E90 4x50 RM 0,6/1kV				
78	42		NHXH FE180/ E90 4x50 RM 0,6/1kV				
79	41		NHXCH FE180/ E90 4x50/25 RM 0,6/1kV				
80	40		NHXCH FE180/ E90 4x50/25 RM 0,6/1kV				
81	39		NHXH FE180/ E90 4x1,5 RE 0,6/1kV	10	Obejma kablowa OZO Mocowanie do betonu co 600 mm za pomocą śruby rozporowej SBO M5x60		
82			NHXH FE180/ E90 4x1,5 RE 0,6/1kV				
83	38		NHXCH FE180/E90 4x1,5/1,5 RE 0,6/1kV				
84			NHXCH FE180/E90 4x1,5/1,5 RE 0,6/1kV				
85	59A		HTKSHekw FE180/90 1x2x0,8				
86	59B		HTKSHekw FE180/90 1x2x0,8				

	Dátum/Date 16.09.2010
	Podpis/Signature <i>Jana S</i>
Dokument č. / Document No. <i>FIRES-FR-191-10-ANKE</i>	
Príloha č./Appendix No. <i>38</i>	

Nr	Nr FIRES	Czas	Symbol kabla (napięcie)	Pozycja	Konstrukcja mocowania, odległość, obciążenie		
87	58		JE-H(St)H.. RE FE180/ E90 2x2x 0.8	12	Obejma kablowa OZSO Mocowanie do betonu co 600 mm za pomocą śruby rozporowej SBO M5x60		
88	57		JE-H(St)H.. RE FE180/ E90 2x2x 0.8				
89	56A		HTKSHekw FE180/90 1x2x0,8				
90	56B		HTKSHekw FE180/90 1x2x0,8				
91	28		HDGs FE180/E90 4x1,0 RE 300/500V				
92			HDGs FE180/E90 4x1,0 RE 300/500V				
93	27		HDGs FE180/E90 4x4,0 RE 300/500V				
94			HDGs FE180/E90 4x4,0 RE 300/500V				
95	55A		HTKSHekw FE180/90 1x2x0,8			13	Uchwyty kablowe UEF. Mocowanie do betonu co 600mm za pomocą kołka KWBO 6x35
96	55B		HTKSHekw FE180/90 1x2x0,8				
97	26		HDGs FE180/E90 4x1,0 RE 300/500V				
98			HDGs FE180/E90 4x1,0 RE 300/500V				
99	25		HDGs FE180/E90 4x4,0 RE 300/500V				
100			HDGs FE180/E90 4x4,0 RE 300/500V				
101	14		NHXH FE180/ E90 4x50 RM 0,6/1kV	14	Uchwyty kablowe UDF. Mocowanie do betonu co 600mm za pomocą kołka GSO 6x40		
102			NHXH FE180/ E90 4x50 RM 0,6/1kV				
103	13		NHXCH FE180/ E90 4x50/25 RM 0,6/1kV				
104			NHXCH FE180/ E90 4x50/25 RM 0,6/1kV				
105	12		NHXH FE180/ E90 4x1,5 RE 0,6/1kV				
106			NHXH FE180/ E90 4x1,5 RE 0,6/1kV				
107	11		NHXCH FE180/E90 4x1,5/1,5 RE 0,6/1kV				
108			NHXCH FE180/E90 4x1,5/1,5 RE 0,6/1kV				
109	53A		HTKSHekw FE180/90 1x2x0,8				
110	53B		HTKSHekw FE180/90 1x2x0,8				
111	10		HDGs FE180/E90 4x1,0 RE 300/500V				
112			HDGs FE180/E90 4x1,0 RE 300/500V				
113	9		HDGs FE180/E90 4x4,0 RE 300/500V				
114			HDGs FE180/E90 4x4,0 RE 300/500V				
115	52A		Securi Flame F 1x2x0,75				
116	52B		Securi Flame F 1x2x0,75				



Dátum/Date: 16. 09. 2010
Podpis/Signature: *Judica S*

Dokument č. / Document No.: *FIRES-FR-191-10-116*

Príloha č./Appendix No.: 39

Zestawienie kabli BITNER:

Lp.	Symbol kabla	Średnica [mm]	Ciężar kabla [kg/m]
1	NHXH FE180/E90 4x1,5RE	14,8	0,32
2	NHXCH FE180/E90 4x1,5RE/1,5	16,2	0,35
3	NHXH FE180/E90 4x50RM	36,2	3,00
4	NHXCH FE180/E90 4x50RM/25	38,3	3,30
5	NHXH FE180/E90 4x4,0RE		
6	JE-H(St)H FE180/E90 2x2x0,8	10,0	0,15
7	HTKSHekw FE180/E90 1x2x0,8	7,5	0,08
8	HDGs FE180/E90 4x1,0RE	10,0	0,11
9	HDGs FE180/E90 4x4,0RE	13,0	0,28
10	HDGsekwf FE180/E90 4x1,0RE	10,3	0,12
11	HDGsekwf FE180/E90 4x4,0RE	13,3	0,30
12	HLGs FE180 FE180/E90 4x1,0		
13	(N)HXH FE180/E90 4x1,5RE	14,8	0,30
14	(N)HXH FE180/E90 5x50RM	41,0	
15	Securi Flame F 1x2x0,75	8,0	0,08

AA

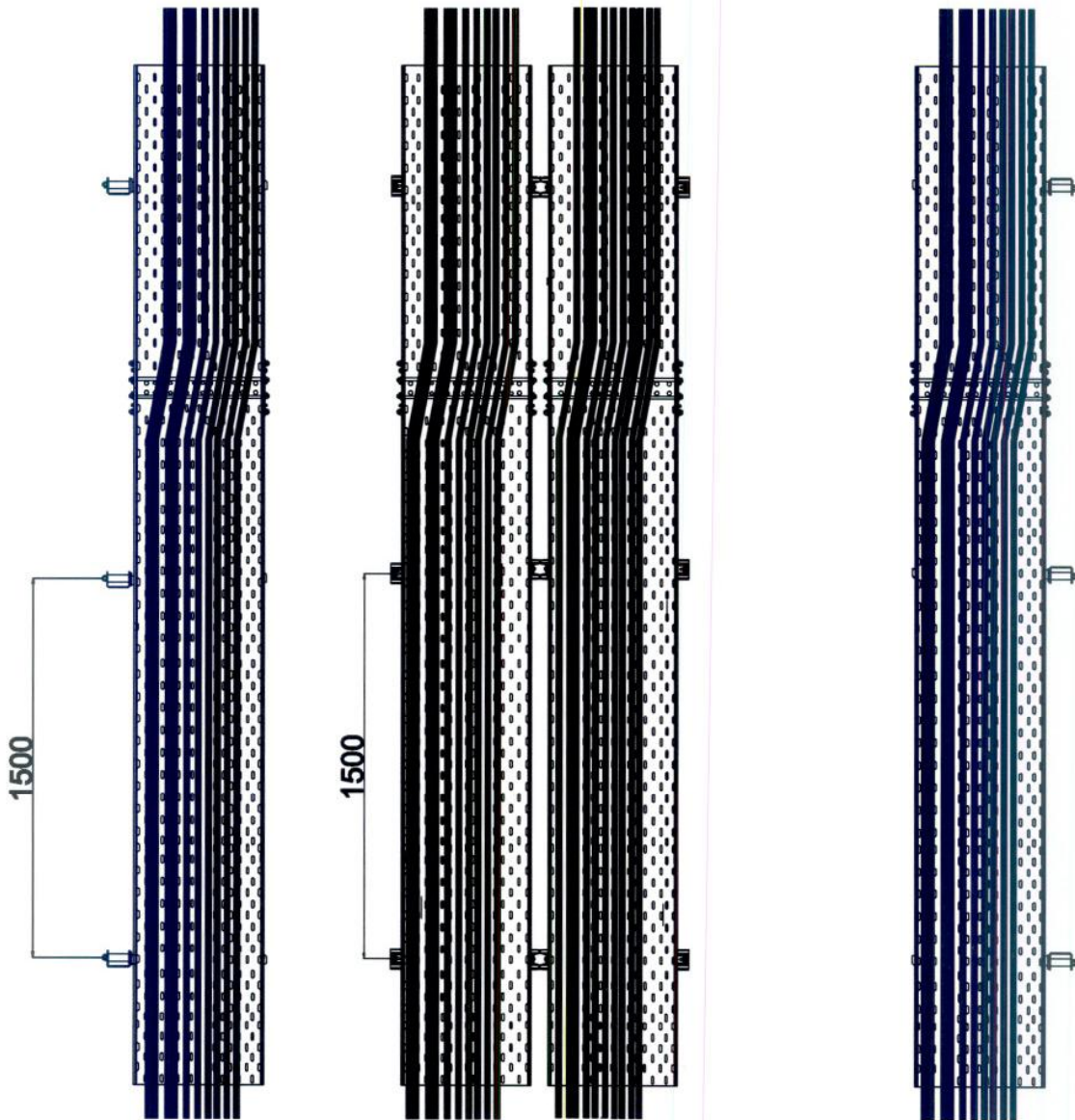

BAKS-BITNER- FIRES
16.09. 2010rok

 FIRES s.r.o. POŽIARNA ODOLNOSŤ FIRE RESISTANCE	Dátum/Date <i>16.09.2010</i>
	<i>Jan S</i> Podpis/Signature
Dokument č. Document No. <i>FIRES-FR-191-10-ANWE</i>	
Príloha č./Appendix No. <i>40</i>	

B-B

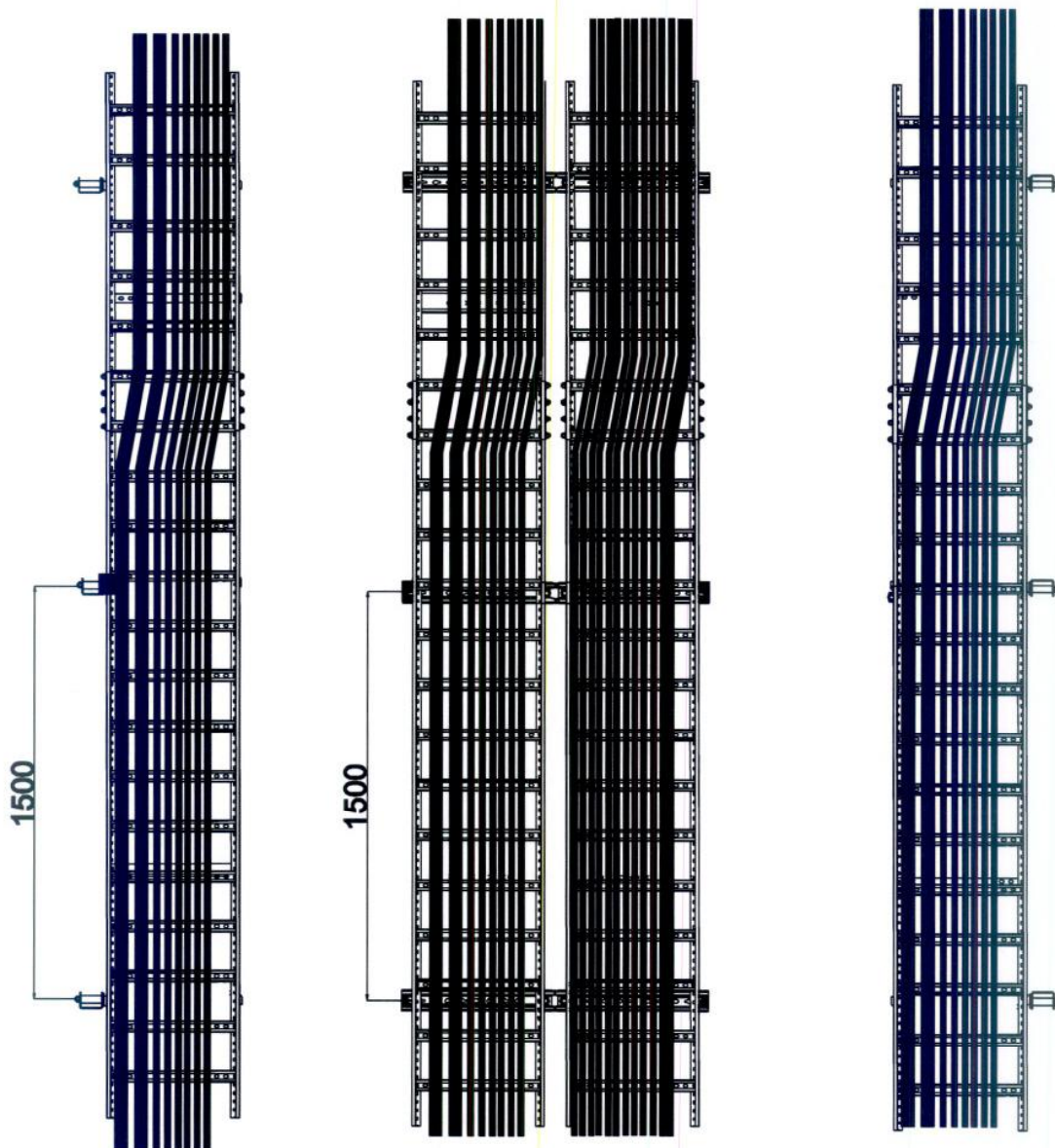



BAKS-BITNER- FIRES
16.09. 2010rok

 FIRES s.r.o. POŽIARNA ODOLNOSŤ FIRE RESISTANCE	Dátum/Date 16. 09. 2010
	<i>Yedrad</i> Podpis/Signature
Dokument č. Document No. <i>FIRES-FR-191-10-DNE</i>	
Príloha č./Appendix No. <i>51</i>	

CC



BAKS-BITNER- FIRES
16.09. 2010rok

 FIRES s.r.o. POŽIARNA ODOLNOSŤ FIRE RESISTANCE	Dátum/Date 16.09.2010
	 Podpis/Signature
Dokument č. <i>FIRES-FR-197-10-ANWE</i> Document No.	
Príloha č./Appendix No. <i>42</i>	

D-D

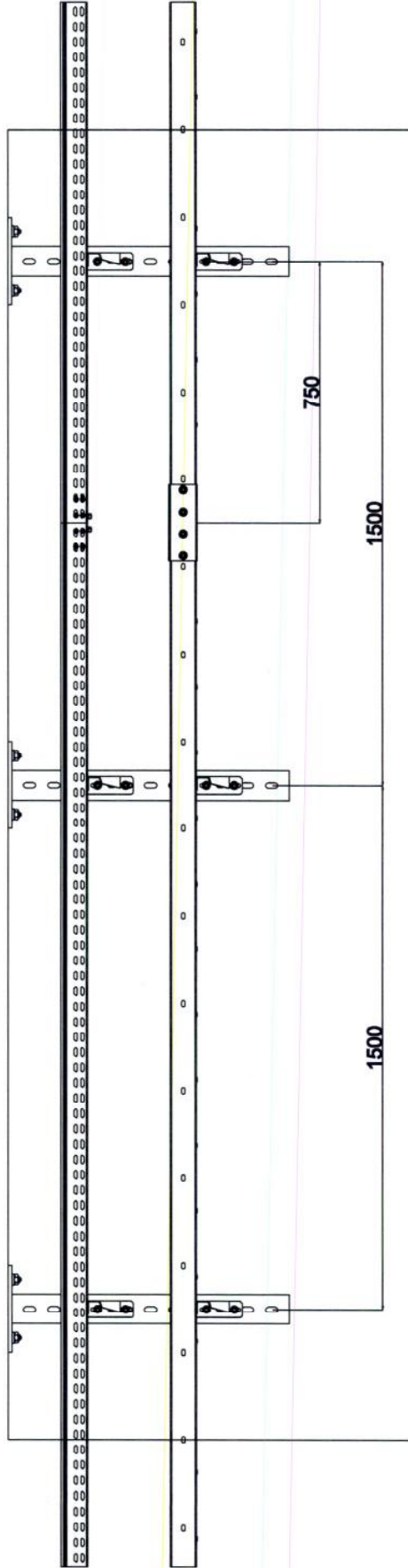

BAKS-BITNER- FIRES
16.09. 2010rok

 FIRES S.R.O. POŽIARNA ODOLNOST FIRE RESISTANCE	Dátum/Date 16.09.2010 Podpis/Signature <i>Yacas</i>
Dokument č. FIRES-FR-111-RO-MWE Document No.	Príloha č./Appendix No. 43

E-E

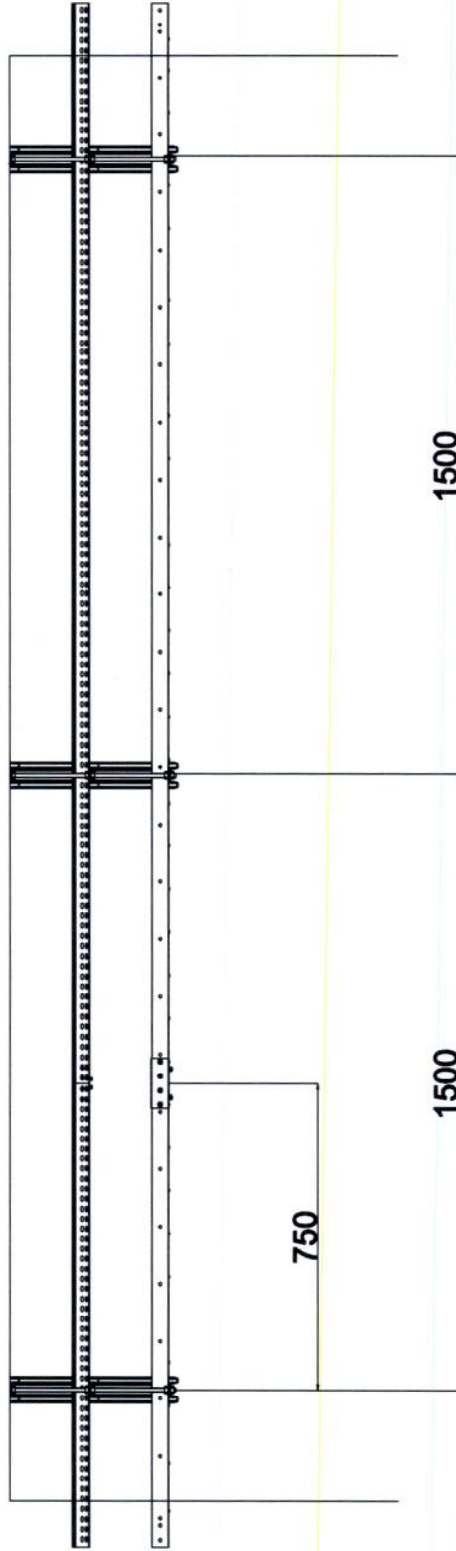

	Dátum/Date 16.09.2010
	Podpis/Signature <i>[Signature]</i>
Dokument č. / Document No. FIRES- FR- 11- 10- 110E	Príloha č./Appendix No. 43

BAKS-BITNER- FIRES
16.09. 2010rok

F-F

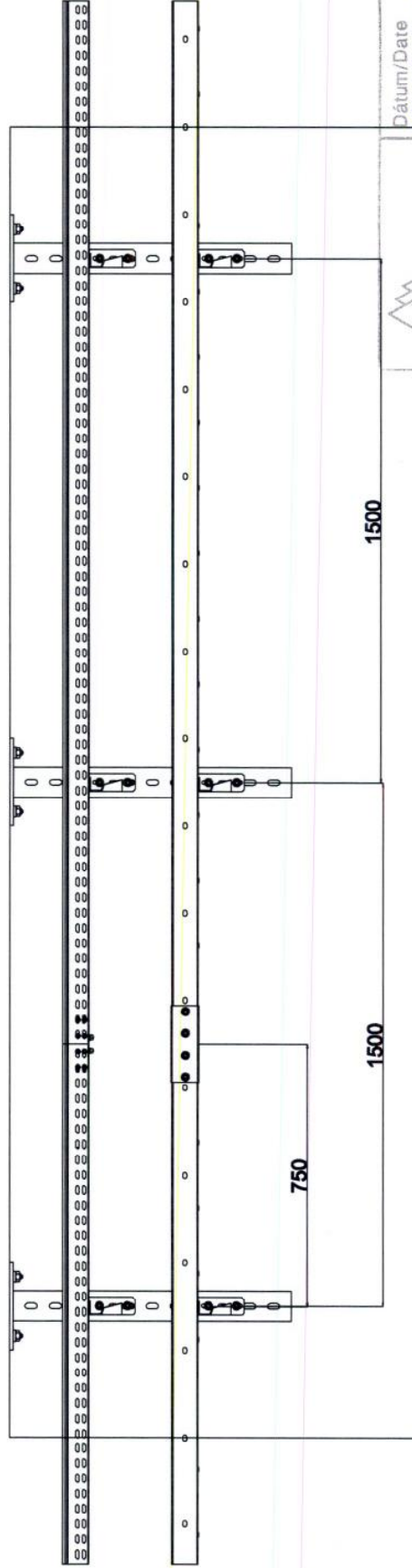

BAKS-BITNER- FIRES
16.09. 2010rok

	Dátum/Date 16.09.2010
Dokument č. FIRES- FIR- MT-02-ANE Document No.	Podpis/Signature <i>Janos</i>
Príloha č./Appendix No. 45	

G-G

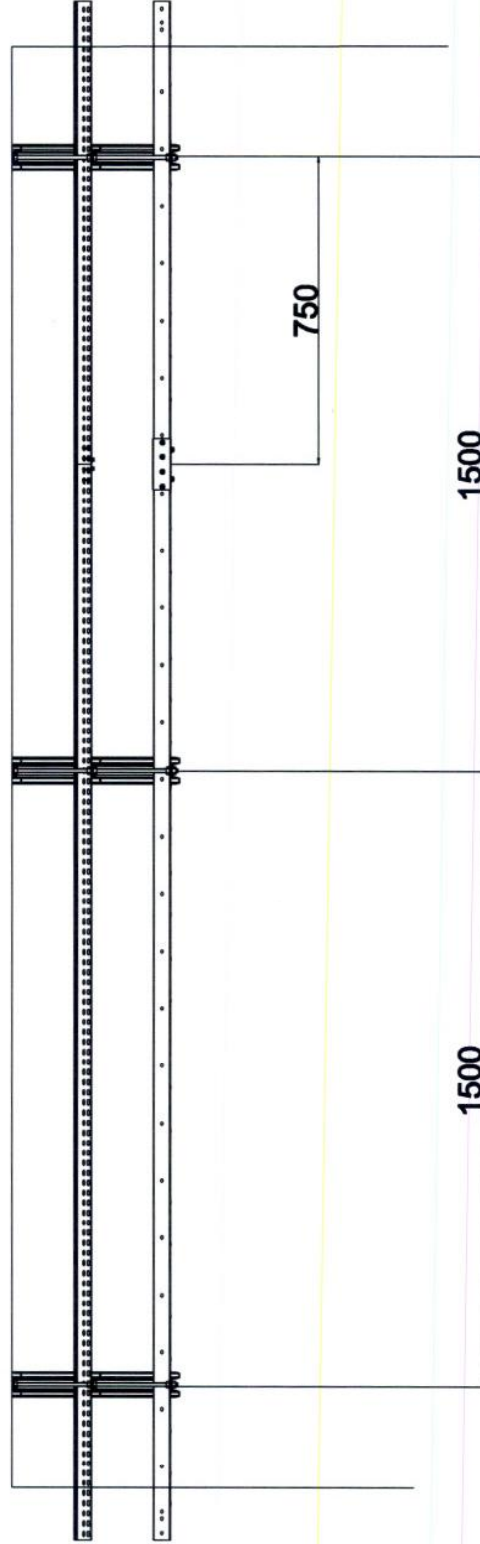

	Dátum/Date 16. 09. 2010
	Podpis/Signature <i>Stanoš</i>
Dokument č. Document No.	FIRES-FR-117-10-AWE
Príloha č./Appendix No.	46

BAKS-BITNER- FIRES
16.09. 2010rok

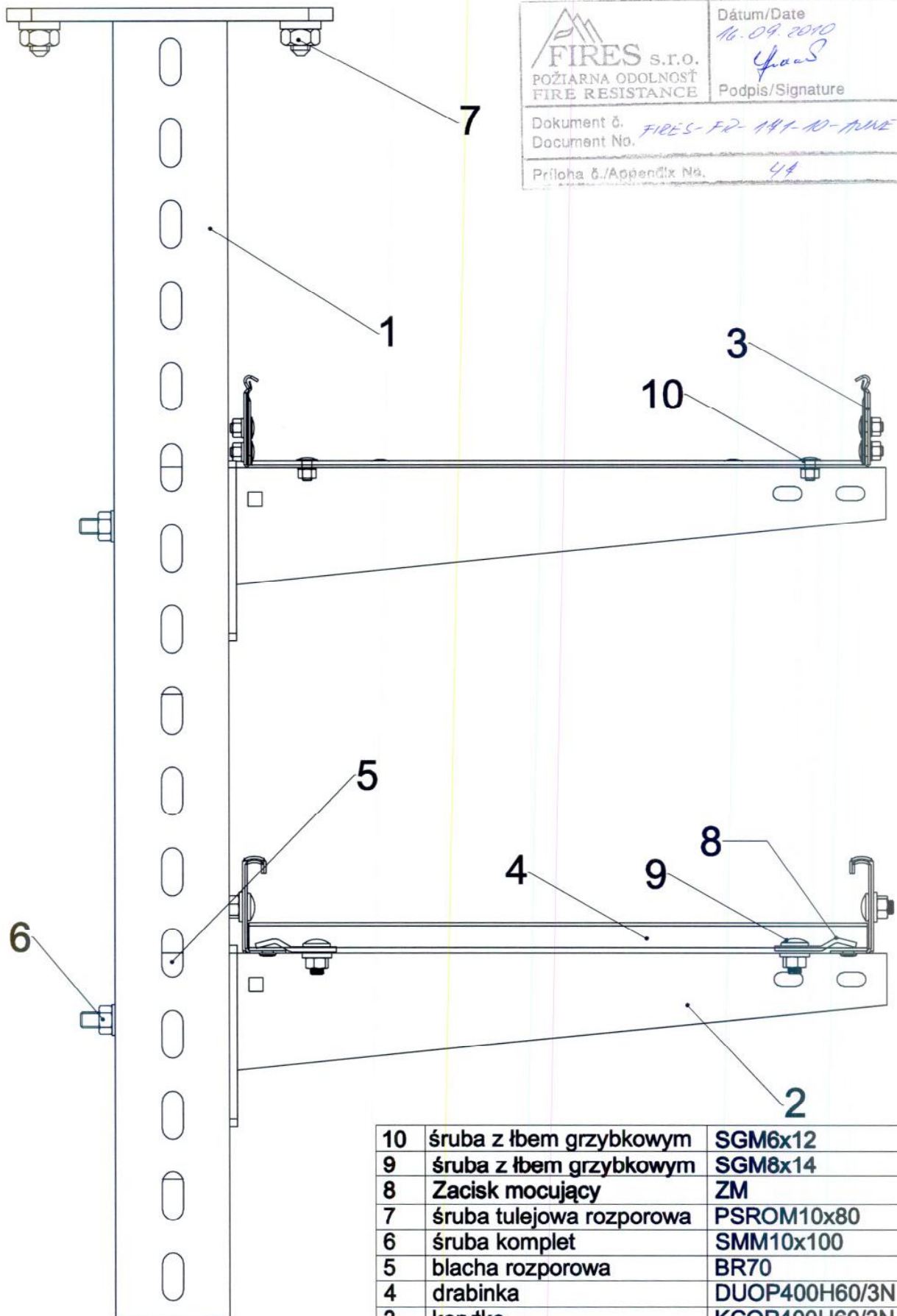

10	šruba z ľbem grzybkowym	SGM6x12	2
9	šruba z ľbem grzybkowym	SGM8x14	2
8	Zacisk mocujúcy	ZM	2
7	šruba tulejowa rozporowa	PSROM10x80	2
6	šruba komplet	SMM10x100	4
5	blacha rozporowa	BR70	2
4	drabinka	DUOP400H60/3N	1
3	korytko	KCOP400H60/3N	1
2	wysięgnik	WWCTO400	2
1	wspornik sufitowy	WPCEO800	1
LP.	NAZWA	SYMBOL	szt.

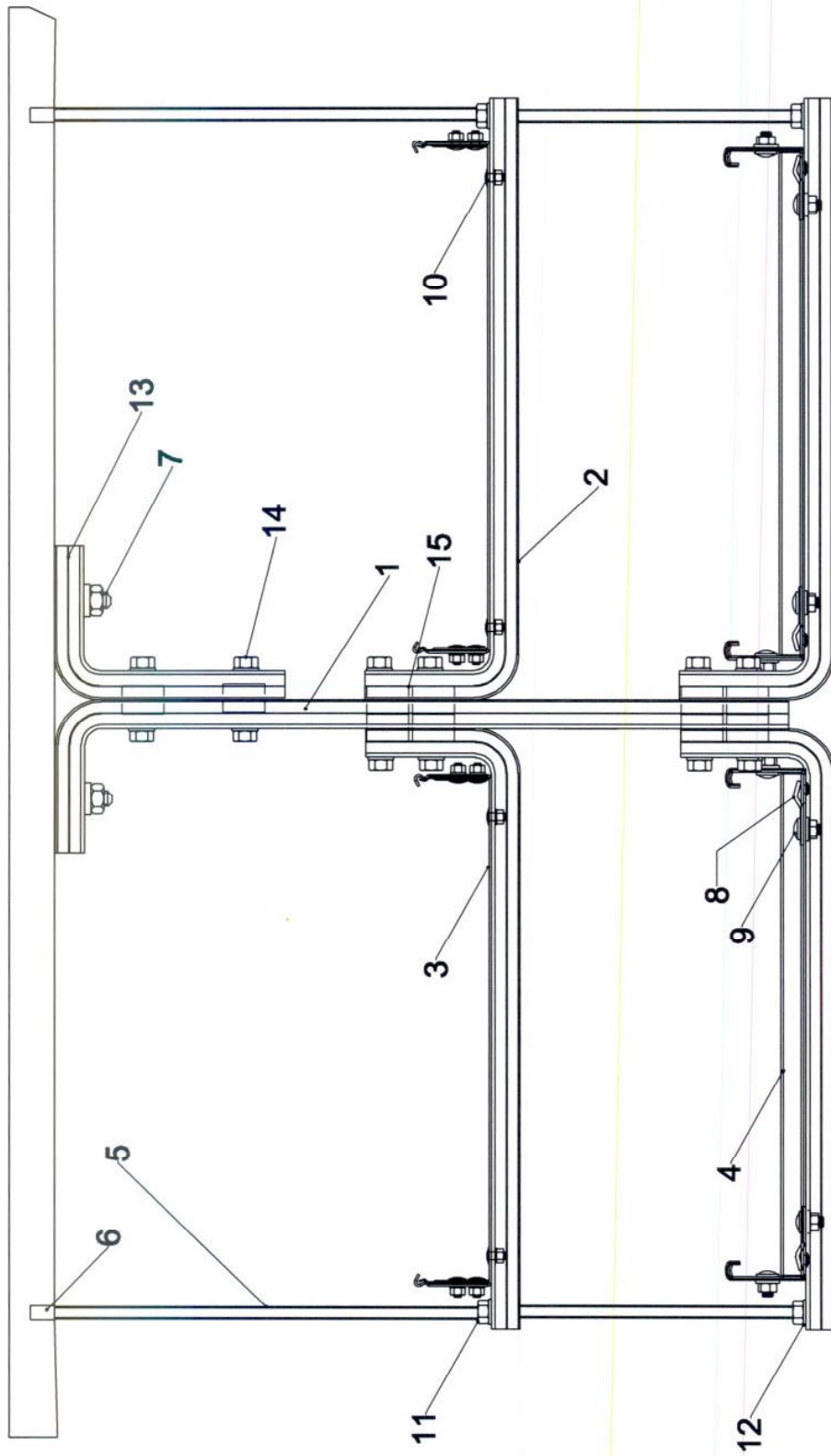

15	Podkładka dystansowa	PD11	10
14	Śruba komplet	SMM10x60	6
13	Wysięgnik	WFO200	1
12	Podkładka	PP10	8
11	Nakrętka	NSM10	8
10	Śruba z łbem grzybkowym	SGM8x12	4
8	Śruba z łbem grzybkowym	SGM8x14	4
8	Zacisk mocujący	ZM	4
7	Śruba tulejowa rozporowa	PSROM10x80	2
6	Tuleja rozporowa	TRSOM10	2
5	Pręt gwintowany	PGM10	2
4	Drabinka	DUOP400H60/N	2
3	Korytko	KCOP400H60/N	2
2	Wysięgnik	WFO400	4
1	Wysięgnik	WFO600	1
LP.	NAZWA	SYMBOL	szk.

<p>FIRES S.r.l. POŻIARNA ODOLNOŚĆ FIRE RESISTANCE</p>	Dátum/Date <i>16.04.2010</i>
	Podpis/Signature <i>Janus</i>
Dokument č. <i>FIRES-FR-M1-D-ANE</i>	
Document No.	
Priloha č./Appendix No. <i>98</i>	

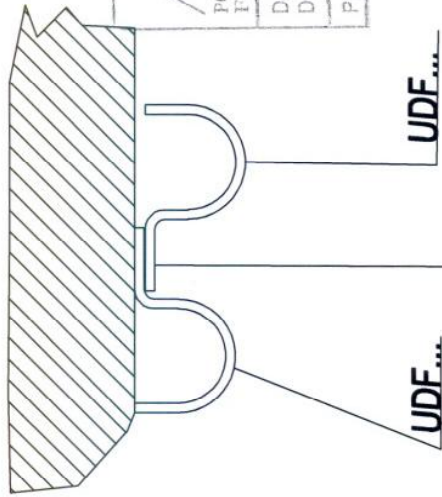

UDE...

Otvor Ø6.5



UDE...

Otvor Ø6.5

FIRES s.r.o.
 POŽIARNA ODOLNOSŤ
 FIRE RESISTANCE
 Dokument č.: *FIRES-FR-111-AD-RWE*
 Document No.: *59*
 Príloha č.: *Asbestidia 112*

Dátum/Date: *16. 09. 2010*
 Podpis/Signature: *[Signature]*

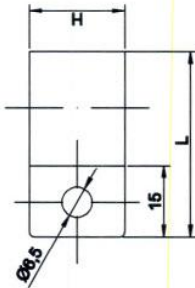

12	Uchwyť kábľa	UDE 20	10,0	39,0	14,0	2,0	
11	Uchwyť kábľa	UDE 18	9,0	37,0	14,0	2,0	
10	Uchwyť kábľa	UDE 16	8,0	35,0	14,0	2,0	
9	Uchwyť kábľa	UDE 15	7,5	34,0	14,0	2,0	
8	Uchwyť kábľa	UDE 14	7,0	33,0	14,0	1,2	
7	Uchwyť kábľa	UDE 12	6,0	30,0	14,0	1,2	
6	Uchwyť kábľa	UDE 10	5,0	28,0	14,0	1,2	
5	Uchwyť kábľa	UDE 9	4,5	27,0	14,0	1,2	
4	Uchwyť kábľa	UDE 8	4,0	26,0	14,0	1,2	
3	Uchwyť kábľa	UDE 7	3,5	25,0	14,0	1,2	
2	Uchwyť kábľa	UDE 6	3,0	24,0	14,0	1,2	
1	Uchwyť kábľa	UDE 5	2,5	23,0	14,0	1,2	
LP	Názvo výrobu	Symbol	Nr. Katalogowy	R [mm]	L [mm]	H [mm]	G [mm]

Dĺžka výška otvoru (okrajov): **±0,5**
 Nr. normy: **PN-EN 10827:2005**
 Název produktu: **UDE 5-20**
 Dátum: **28.07.09**
 Miesto: **G. Mankassovci**
 Projektant: **[Signature]**
 Rysoval: **[Signature]**
 Spracoval: **[Signature]**
 Zkontroloval: **[Signature]**
 Miesto: **[Signature]**
 Nr. objednávky: **[Signature]**
Profesjonálne Systémy Trús Kablových

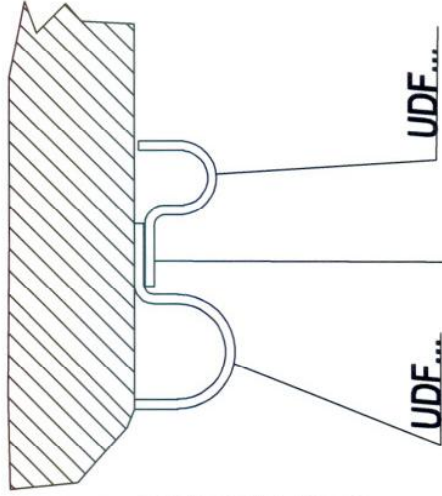

UDE...

Otvor Ø6.5

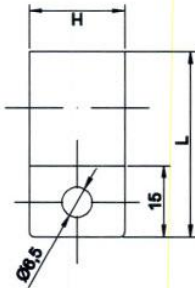

12	Uchwyť kábľa	UDE 20	10,0	39,0	14,0	2,0	
11	Uchwyť kábľa	UDE 18	9,0	37,0	14,0	2,0	
10	Uchwyť kábľa	UDE 16	8,0	35,0	14,0	2,0	
9	Uchwyť kábľa	UDE 15	7,5	34,0	14,0	2,0	
8	Uchwyť kábľa	UDE 14	7,0	33,0	14,0	1,2	
7	Uchwyť kábľa	UDE 12	6,0	30,0	14,0	1,2	
6	Uchwyť kábľa	UDE 10	5,0	28,0	14,0	1,2	
5	Uchwyť kábľa	UDE 9	4,5	27,0	14,0	1,2	
4	Uchwyť kábľa	UDE 8	4,0	26,0	14,0	1,2	
3	Uchwyť kábľa	UDE 7	3,5	25,0	14,0	1,2	
2	Uchwyť kábľa	UDE 6	3,0	24,0	14,0	1,2	
1	Uchwyť kábľa	UDE 5	2,5	23,0	14,0	1,2	
LP	Názvo výrobu	Symbol	Nr. Katalogowy	R [mm]	L [mm]	H [mm]	G [mm]

Dĺžka výška otvoru (okrajov): **±0,5**
 Nr. normy: **PN-EN 10827:2005**
 Název produktu: **UDE 5-20**
 Dátum: **28.07.09**
 Miesto: **G. Mankassovci**
 Projektant: **[Signature]**
 Rysoval: **[Signature]**
 Spracoval: **[Signature]**
 Zkontroloval: **[Signature]**
 Miesto: **[Signature]**
 Nr. objednávky: **[Signature]**
Profesjonálne Systémy Trús Kablových

A	Typ	Nr.kat
100	KCDP100H60/3N	862010
200	KCDP200H60/3N	862020
300	KCDP300H60/3N	862030
400	KCDP400H60/3N	862040

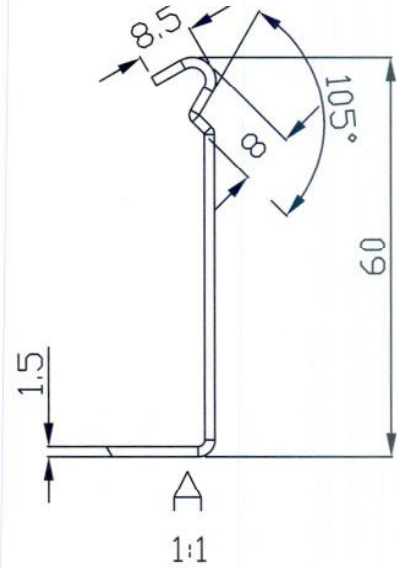
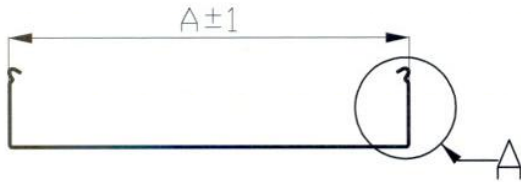

FIRES s.i.o. POŻIARNA ODOLNOŚĆ FIRE RESISTANCE	Dátum/Date 16. 09. 2010
	Podpis/Signature
Dokument č. / Document No. <i>FIRES-FP-111-10-111E</i>	
Příloha č./Appendix No. <i>50</i>	

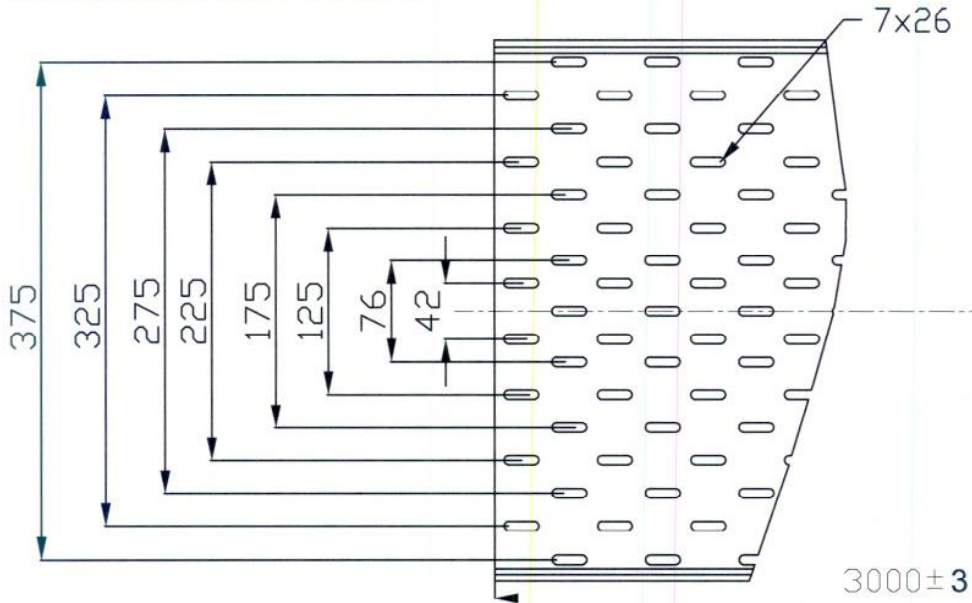
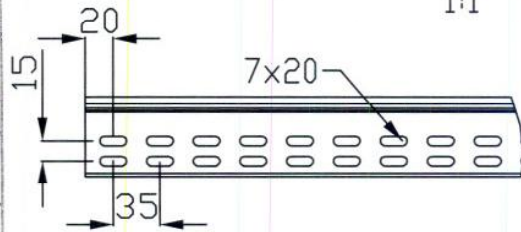

Odchylka (wyniarów) nietolerowanych	Materiał Gatunek Nr normy półfabrykat (nr normy)	PN-EN 10142 + A1 : 1997	Masa [kg]	Podziałka	Format A4
					Arkusz
Projektował	J.GROCHOWSKI	20.10.05	Nazwa rysunku		
Rysował	J.Grochowski	20.10.05	KCDP400H60/3N		
Sprawdził	T.WŁODARCZYK	20.10.05			
Zatwierdził	JKLICZEK	20.10.05	Nr programu maszynowego	Nr ziany	
Profesjonalne Systemy Tras Kablowych			Nr rysunku 862040		

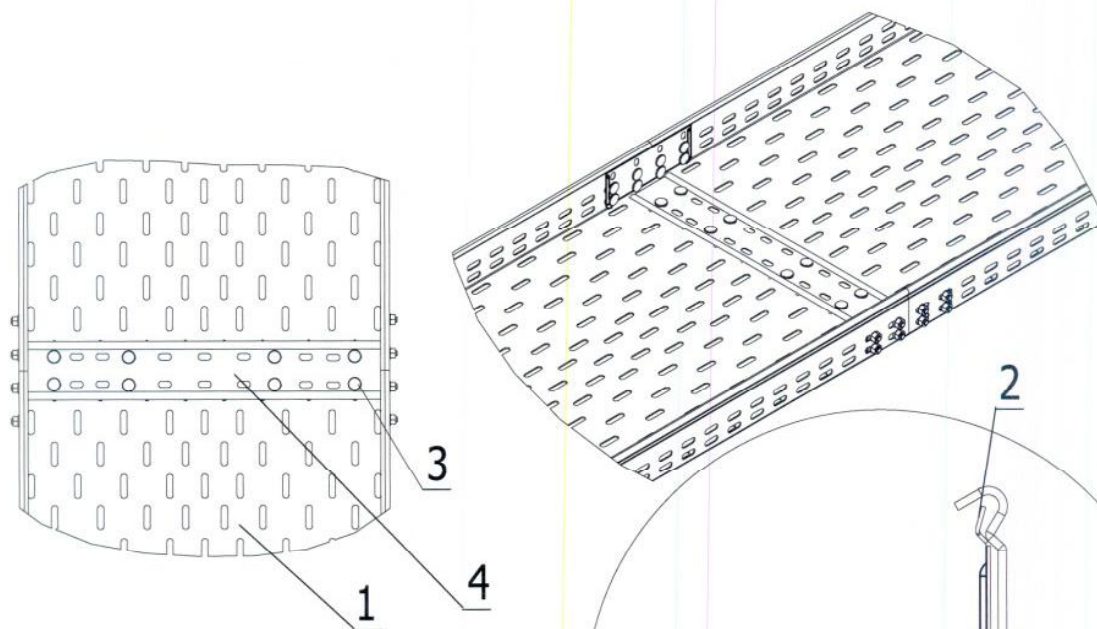
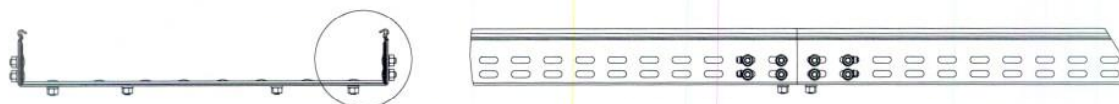



Poz.1		Poz.4
A	Typ	Typ
100	KCDP100H60/3	BLD100
200	KCDP200H60/3	BLD200
300	KCDP300H60/3	BLD300
400	KCDP400H60/3	BLD400

	Datum/Date 16.08.2010
	Podpis/Signature <i>J. Grochowski</i>
Dokument č. / Document No. <i>FIRES-FD-191-10-ANNE</i>	
Příloha č./Appendix No. <i>51</i>	

4	Błacha łącznikowa	BLD400	1
3	śruba	SGN M6x12	24
2	łącznik	LPDPH60	2
1	koryto	KCDP400H60/3	1
poz.	nazwa	symbol	sztuk

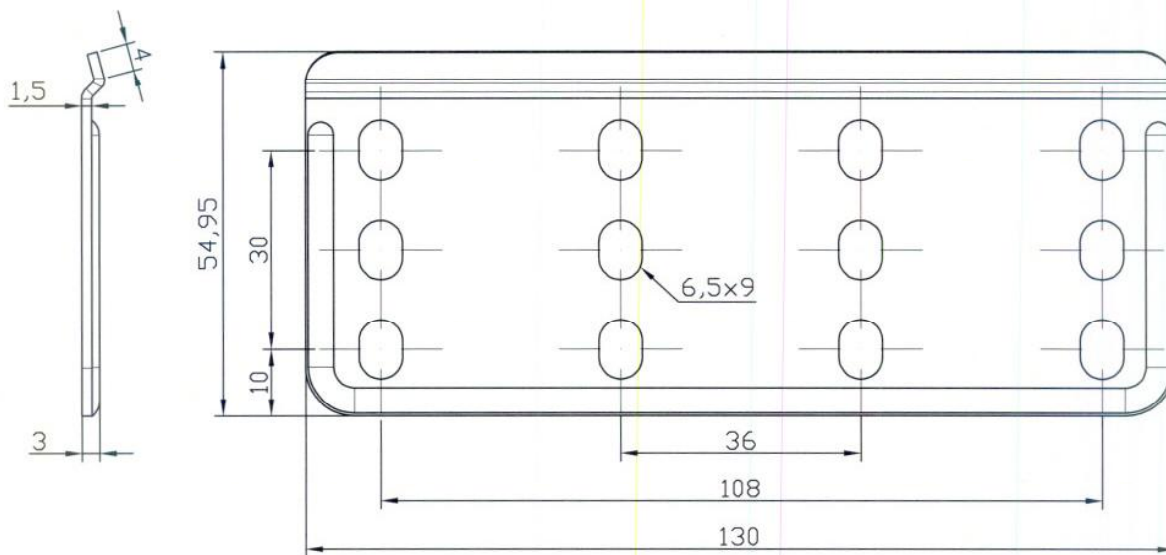
	Dachylka wymiarów nieterowanych	Materiał Gatunek Nr normy półfabrykat (nr normy)	Masa (kg)	Podziałka 7:50	Format A4 Arkusz 1 Arkuszy 1
Rysował	Nazwisko J. Grochowski	Podpis	Data 09.04.2010		
Sprawdził					
Zatwierdził				Nr programu maszynowego	Nr zmiany



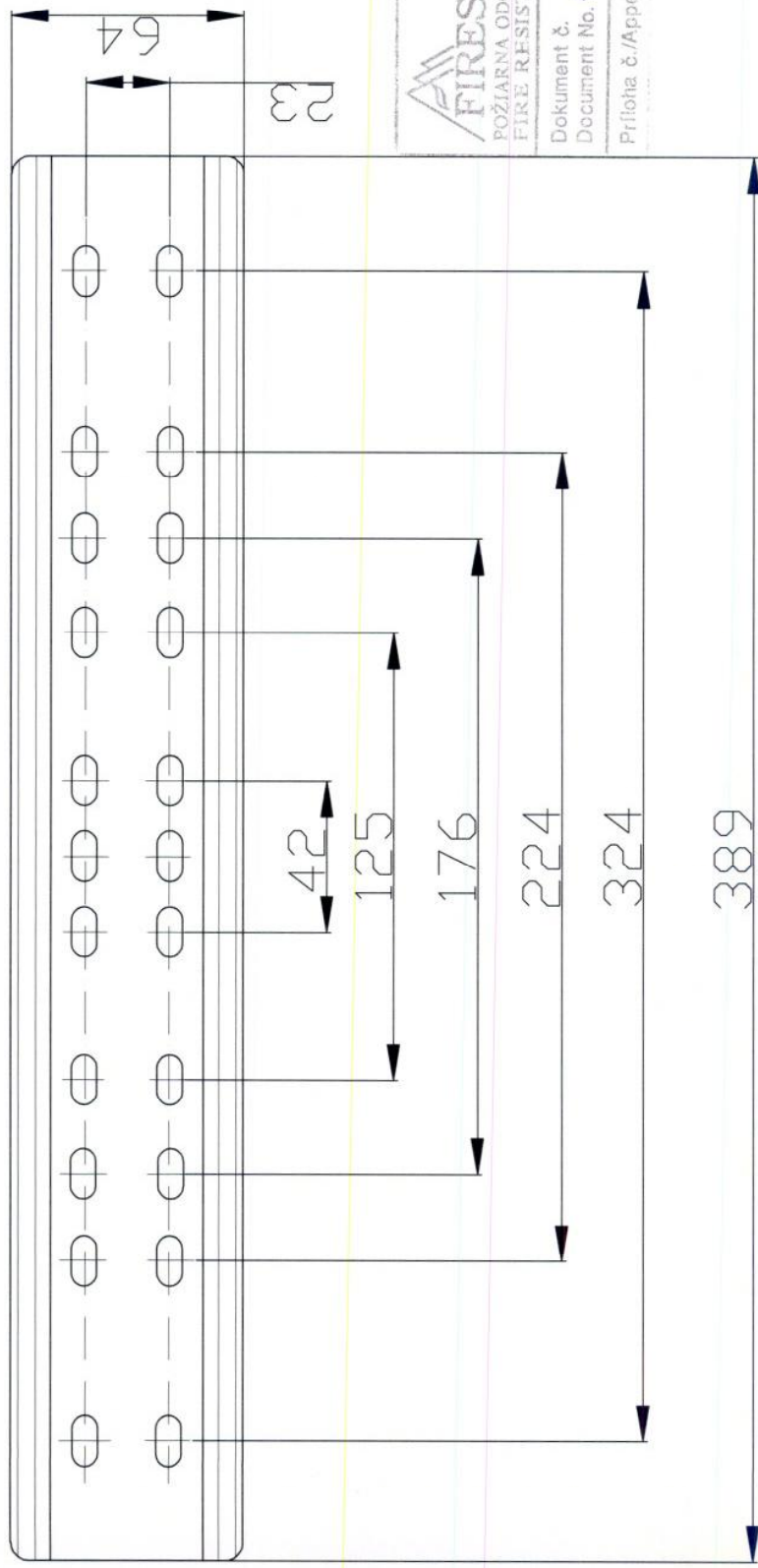
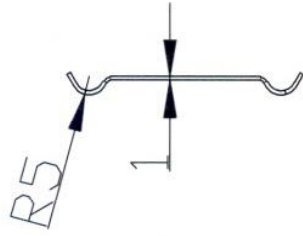

 FIRES s.r.o. POZIARNA ODOLNOST' FIRE RESISTANCE	Datum/Date 16.09.2010
	 Podpis/Signature
Dokument č. Document No.	FIRES-FD-M1-10-AME
Príloha č./Appendix No.	50

	Dłchytko wymiarów nietolerowanych		Materiał Gatunek Nr normy półfabrykat (nr normy)	Masa [kg] PN-EN 10327:2005	Podziałka 1:1	Format A4 Arkusz Arkuszy
 Profesjonalne Systemy Tras Kablowych						





FIRES s.r.o.
 POŽIARNA ODOLNOSŤ
 FIRE RESISTANCE
 Dátum/Date: 16.09.2010
 Podpis/Signature: [Signature]
 Dokument č. FIRES-FR-M1-M-RAVE
 Document No.
 Príloha č./Appendix No. 53

 Projekt  Číslo  Zmena	JGDODU/SKZ JGDODU/SKZ T.M. ODARČZYK JALICZEK	Názov výrobku BLD400N Blachna taczniakowa	Max. Dłg. 0,13	Podklad 111	Formát A2
	Nr. sprawy 2010/05 2010/05 2010/05	Nr. rysunku 862420	Nr. zmiany	Nr. rysunku	Nr. zmiany
Profesjonalne Systemy Trus Kablowych					

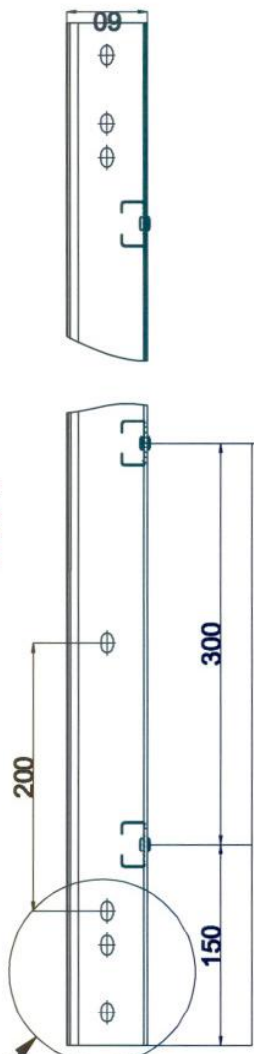
A-A

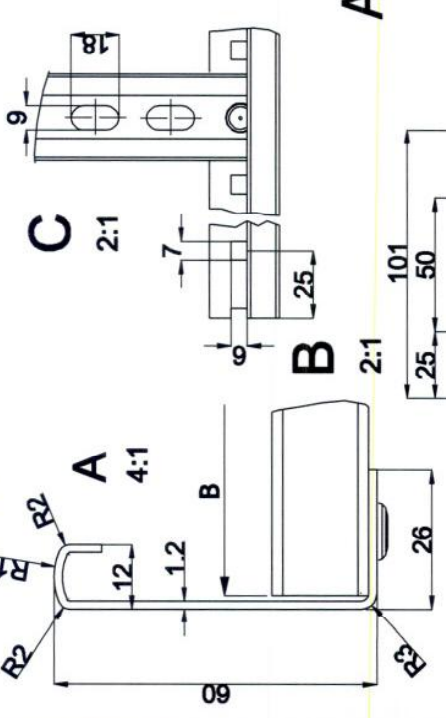

B



A

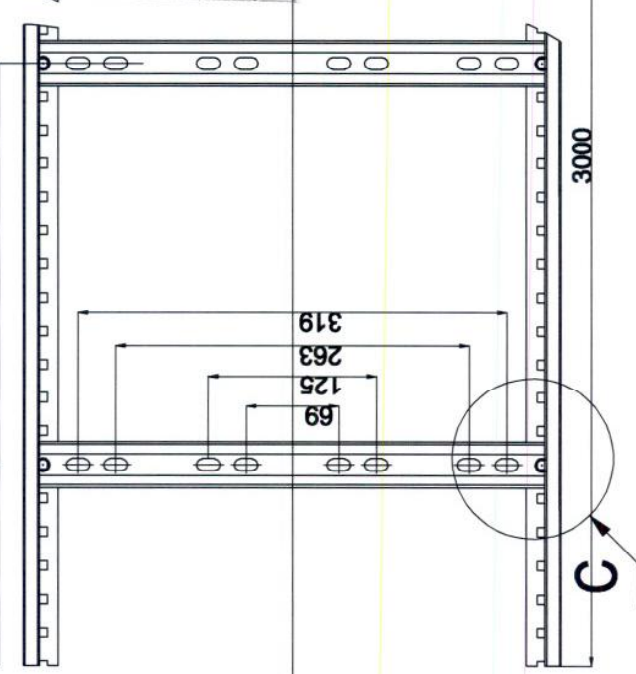

3000

C

400

A

FIRE S.I.O. POZIARNA ODOLNOST' FIRE RESISTANCE	Dátum/Date <i>16.09.2010</i>
Dokument č. Document No. 0	Podpis/Signature <i>Y. G. S.</i>
Priloha č./A. Appendix No. 54	<i>FIRE-FR-M-10-PNE</i>

A	Typ	L
100	DUOP100H60/6N	6000
200	DUOP200H60/6N	6000
300	DUOP300H60/6N	6000
400	DUOP400H60/6N	6000
100	DUOP100H60/3N	3000
200	DUOP200H60/3N	3000
300	DUOP300H60/3N	3000
400	DUOP400H60/3N	3000

Projektował	Długość wymiarów nie tolerowanych	Material	Podziałka	Forma	A4
Rysował	nie tolerowanych	28.01.09	1:5	Klasa	
Sprawił	G. Makowski	DUOP400H60/3N		Klasyfikacja	
Zatwierdził	DRABINA				
Profesjonalne Systemy Tras Kablowych				Nr zmiany	
BANS					

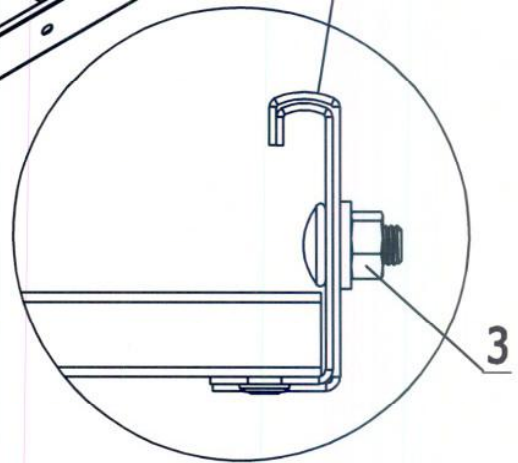
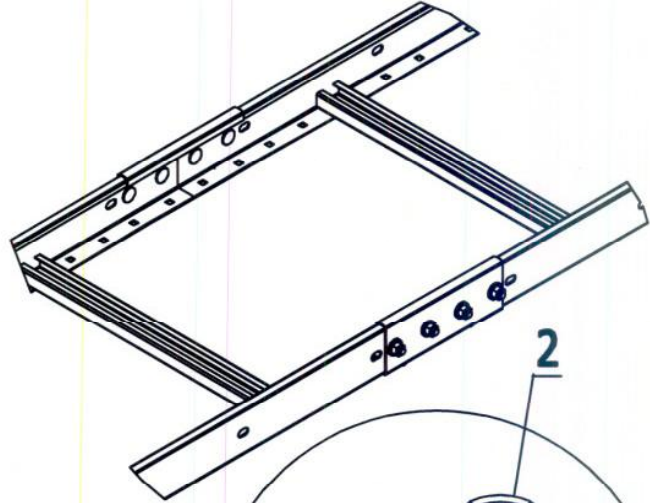
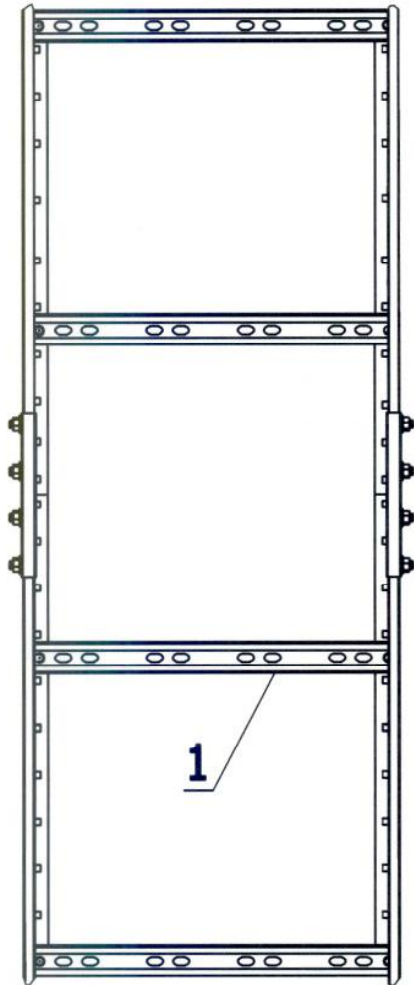

FIRES s.r.o. POZIARNA ODOLNOST' FIRE RESISTANCE	Dátum/Date 16.09.2010
	Podpis/Signature
Dokument č./Document No. <i>FIRES-FR-147-10-ANWE</i>	
Příloha č./Appendix No. <i>55</i>	

3	sruba	SGN M8x14		8	
2	lacznik	L.DDNC60N		2	
1	DRABINA	DUDP400H60/3N		2	
Pos.	Benennung	Zeichnung-Nr	Material	Stck.	Katalogs Nr.
Dłochyłka wyniarów nietolerowanych	Material		Gatunek	Masa (kg)	Podzialka
			Nr normy		format A4
			polfabrykat (nr normy)		Arkusz 1
Projektował	Nazwisko Grochowskił	Podpis _____	Data 30-06-09	Nazwa rysunku DUDP400H60/3N	
Rysował				Nr programu maszynowego	
Sprawdzil				Nr rysunku	
Zatwierdzil				Nr zmiany	
Profesjonalne Systemy Tras Kablowych					

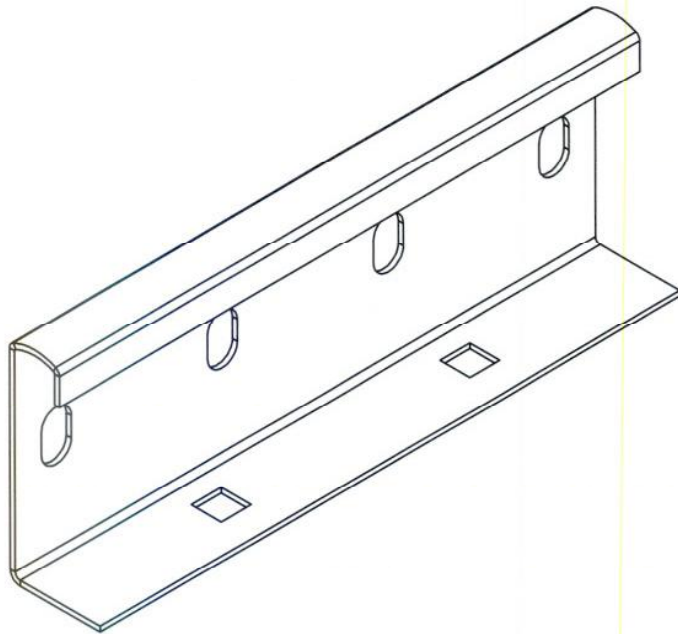



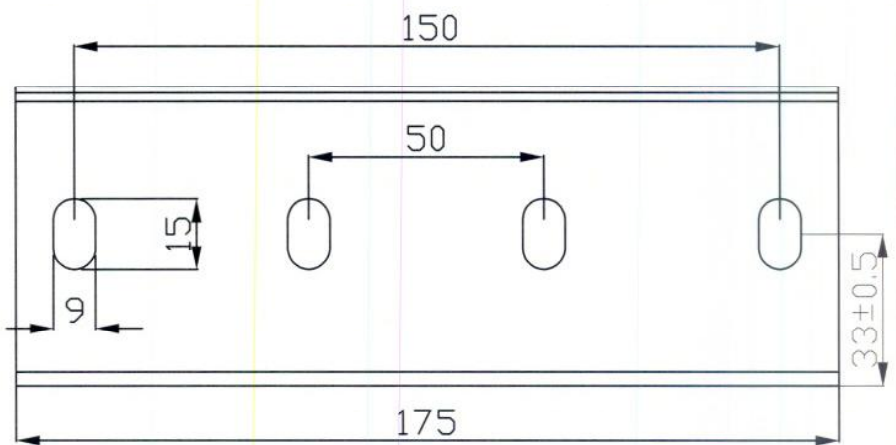
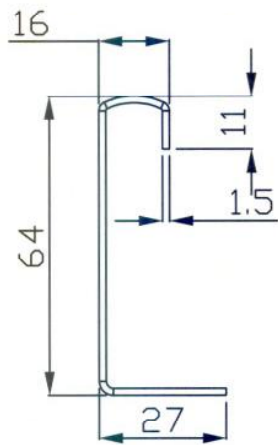
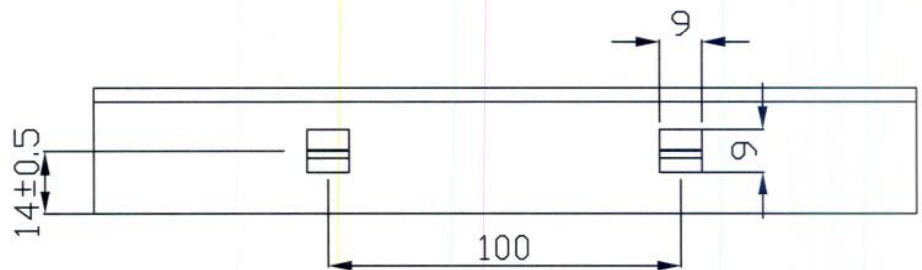

 FIRES s.r.o. POŽIARNA ODOLNOSŤ FIRE RESISTANCE	Dátum/Date 16.09.2010
	 Podpis/Signature
Dokument č. / Document No. <i>FIRES-FR-191-10-1711E</i>	
Príloha č./Appendix No. <i>56</i>	

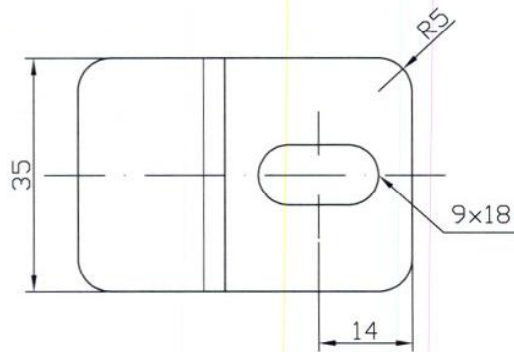
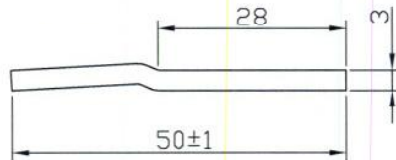



	Dłochyłka wymiarów nietolerowanych		Materiał Gatunek Nr normy półfabrykat (nr normy)	Masa [kg] Podziałka	Format A4 Arkusz Arkuszy
	Projektował	J.GROCHOWSKI			
Rysował	J.Grochowski	Podpis	20.10.05	Nazwa rysunku <i>L DDCNH60</i>	
Sprawdził	T.WŁODARCZYK		20.10.05	Nr programu	
Zatwierdził	J.KLICZEK		20.10.05	Nazwy 863000 Nr zleńy	

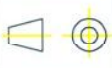

 FIRES S.T.O. POZIARNA ODOLNOST' FIRE RESISTANCE	Datum/Date 16.09.2010
	 Podpis/Signature
Dokument č./Document No. <i>FIRES-FZ-111-10-1101E</i>	
Priloha č./Appendix No. <i>51</i>	

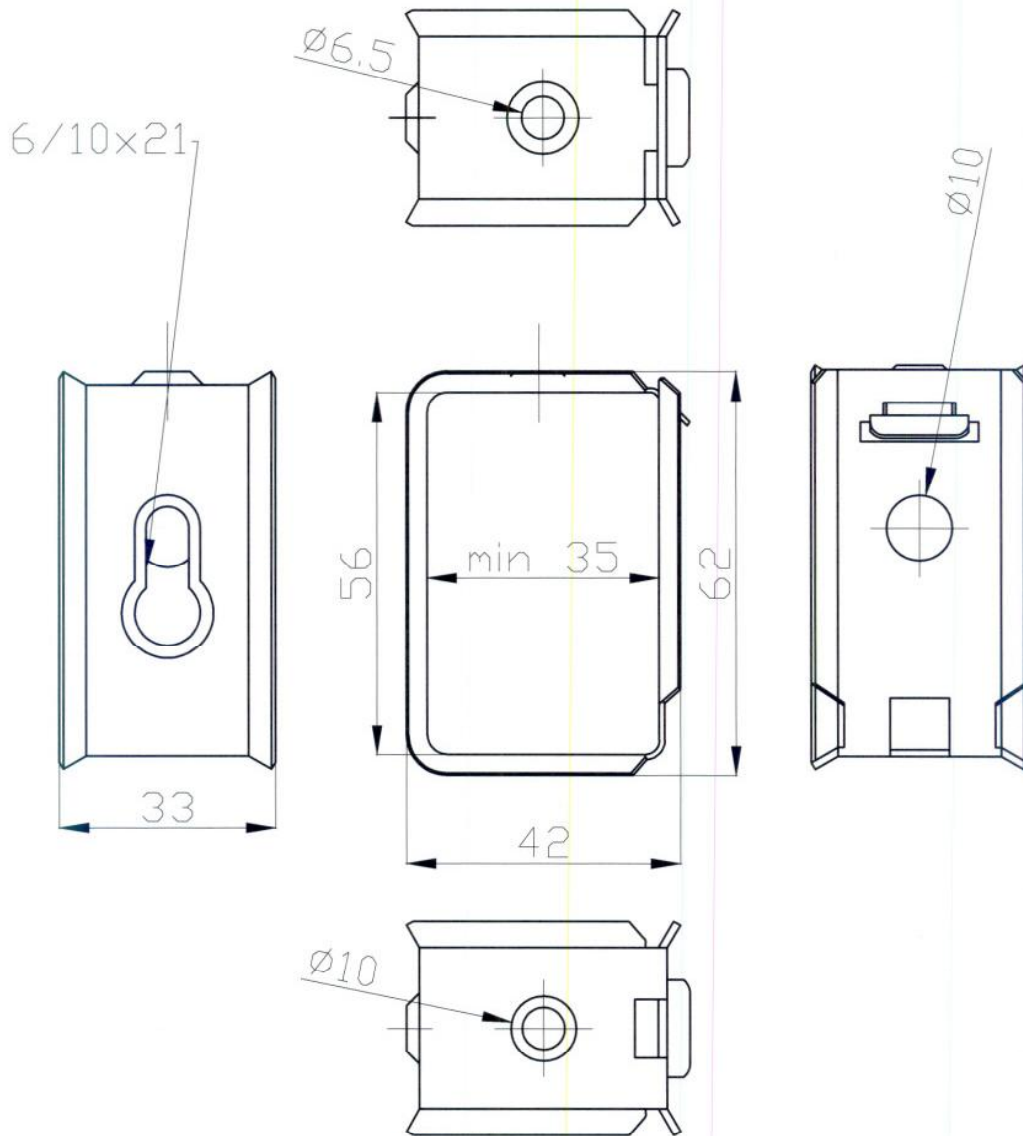
	Odchyłka wymiarów nietolerowanych $\pm 0,5$	Gatunek Nr normy półfabrykat (nr normy)	---- PN-EN 10327:2005 ----	Masa [kg] 0,025	Podziałka 1:1	Format A4 Arkusz -- Arkuszy --												
	Projektował Rysował Sprawdził Zatwierdził	Tomasz Grudniewski Jakub Rudak Jacek Kliczek Jacek Kliczek	Podpis _____ _____ _____	Data 29.12.04 20.02.08 20.02.08 20.02.08	Nazwa rysunku <div style="font-size: 2em; text-align: center;">ZMOE</div>		Nr zbilansy											
 Profesjonalne Systemy Tras Kablowych			Nr rysunku <div style="font-size: 2em; text-align: center;">802900</div>	<table border="1" style="width: 100%; height: 40px;"> <tr><td></td><td></td><td></td><td></td></tr> <tr><td></td><td></td><td></td><td></td></tr> <tr><td></td><td></td><td></td><td></td></tr> </table>														

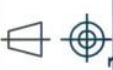

	Odchytká wymiarów nietolerowanych		Materiál Gatunek Nr normy Półfabrykat (nr normy)		Masa (kg)	Podzielka 1:1	Format A4			
							Arkusz 1 Arkuszy			
Projektował	Nazwisko G. Matuszewski	Podpis _____	Data 2010.06.04	Nazwa rysunku <i>Objejmia OZMO</i>						
Rysował										
Sprawdził										
Zatwierdził										
				Nr programu maszynowego			Nr zmlany			
 Profesjonalne Systemy Tras Kablowych				Nr rysunku						

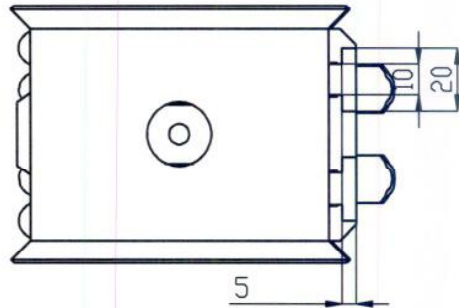
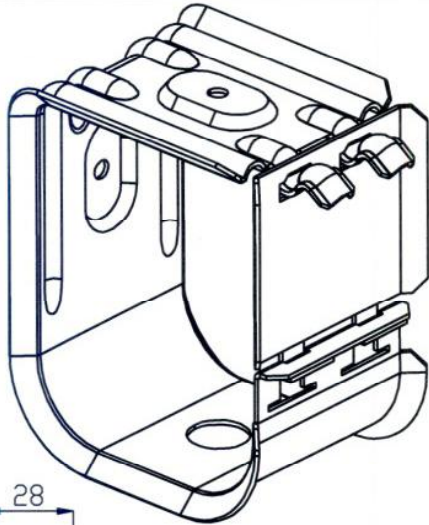

B-B

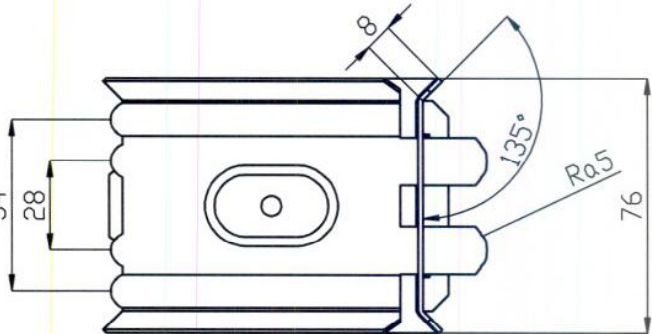
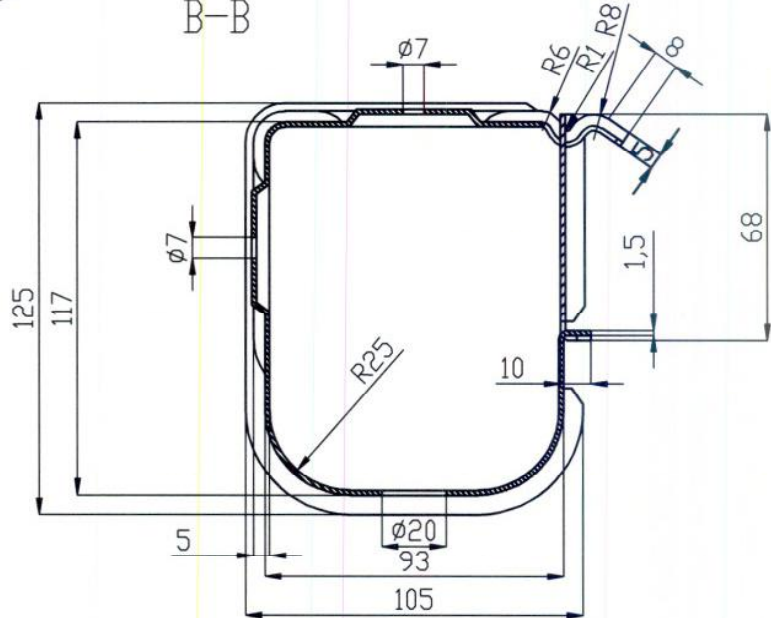
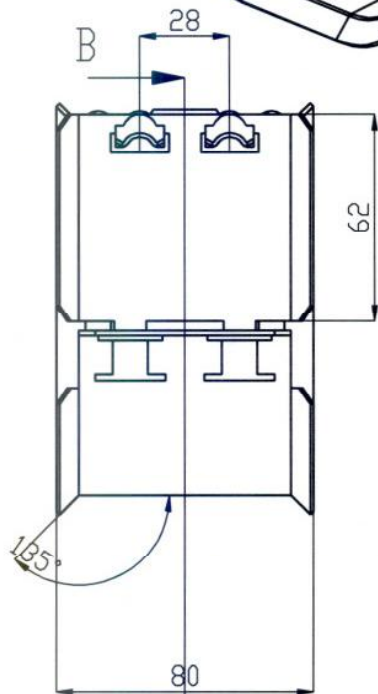

	Datum/Date 16. 09. 2010
	Podpis/Signature <i>Juan S</i>
	Dokument č. Document No. <i>FIRES-FR-191-10-ANNE</i>
	Príloha č./Appendix No. <i>59</i>

	Dýchytka wyniarów nietolerowanych	Gatunek Nr normy półfabrykat (nr normy)	Masa (kg)	Podziałka 1:2	Format A4 Arkusz 1 Arkuszy 1
Rysował T.Grudniewski	Podpis	Data	Nr programu maszynowego		
Sprawdził J.Kliczek		Data	Nr rysunku		
Zatwierdził J.Kliczek	Profesjonalne Systemy Tras Kablowych			Nr zniary	

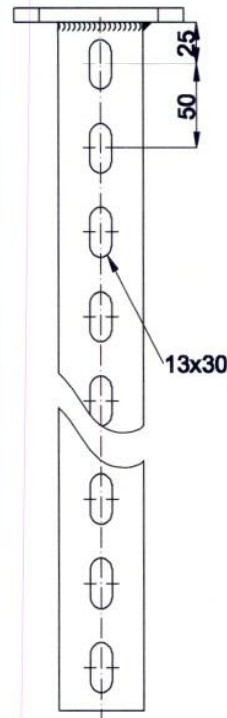
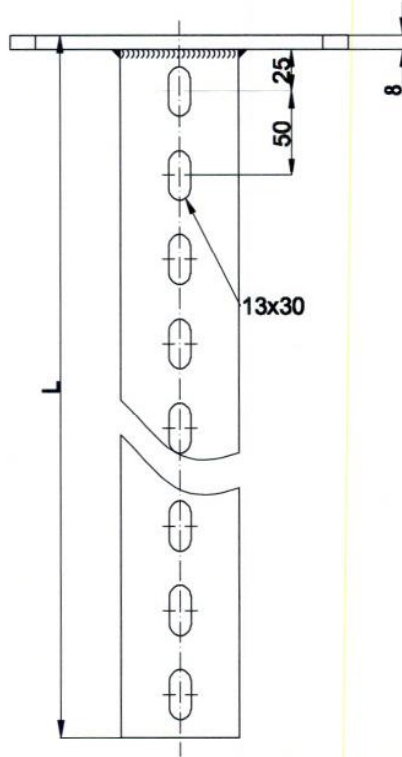
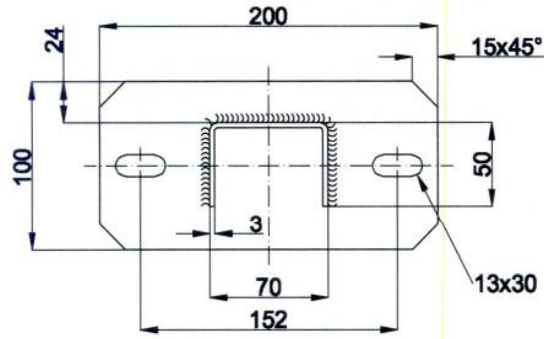

 FIRES S.I.O. POŻIARNA ODOLNOŚĆ FIRE RESISTANCE	Datum/Date 16.08.2010 Podpis/Signature
	Dokument č. Document No. <i>FIRES-FR-111-10-ANE</i>
Príloha č./Appendix No. <i>60</i>	

10	Wspornik sufitowy	WPCE02000	2000
9	Wspornik sufitowy	WPCE01000	1000
8	Wspornik sufitowy	WPCE0900	900
7	Wspornik sufitowy	WPCE0800	800
6	Wspornik sufitowy	WPCE0700	700
5	Wspornik sufitowy	WPCE0600	600
4	Wspornik sufitowy	WPCE0500	500
3	Wspornik sufitowy	WPCE0400	400
2	Wspornik sufitowy	WPCE0300	300
1	Wspornik sufitowy	WPCE0200	200
LP	Nazwa wyrobu	Symbol	L

	Długość wymiarów nietolerowanych		Gatunek Nr normy półfabrykat (nr normy)	PN-EN 10327:2005 —	Masa [kg] —	Podziałka 1:4	Format A4 Arkusze — Arkuszy —
	Projektował Rysował Sprawdził Zatwierdził	Nazwisko G. Matuszewski Podpis _____ _____ _____					
Profesjonalne Systemy Tras Kablowych				Nr rysunku	Nr zmiany		

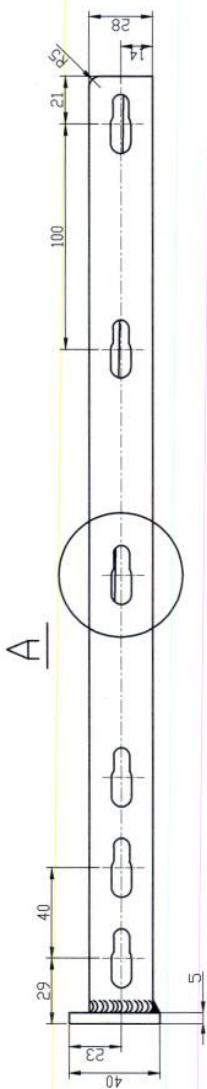
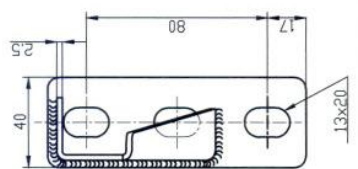
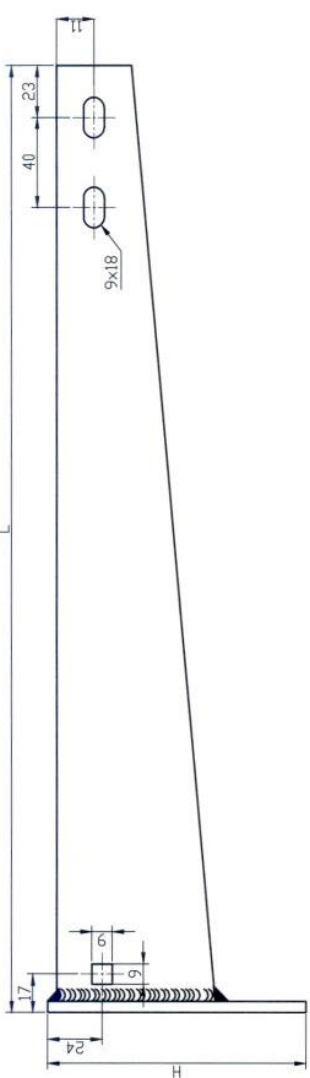

A 2:1

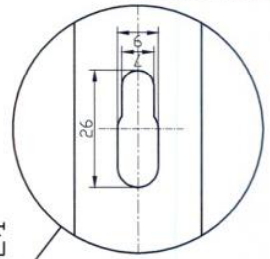

	Dátum/Date	16. 09. 2010
	Podpis/Signature	<i>Jacek</i>
POŽIARNÁ ODOLNOSŤ FIRE RESISTANCE	Dokument č.	FIRES-FR-141-10-PAE
	Document No.	
	Príloha č./Appendix No.	61

4 Výšegrad	WMCD 400	800340	114,0	420	0,83	
3 Výšegrad	WMCD 300	800330	114,0	320	0,43	
2 Výšegrad	WMCD 200	800320	85,0	220	0,36	
1 Výšegrad	WMCD 100	800310	85,0	120	0,22	
LP	Názva výrobu	Symbol	Nr. katalogový	L [mm]	H [mm]	Masa [kg]
	±0,5	0,1	PM-EN ISO 14642:2000	11	11	11
Dávkovanie výrobku (rehabilitovaných) Tonaz Grublerová Jolanda Rudoš Jacek Klizerek Jacek Klizerek	Projektant Projekt 20.02.08 20.02.08	Výrobca 20.02.08 20.02.08	Výrobca 20.02.08 20.02.08	Výrobca 20.02.08 20.02.08	Výrobca 20.02.08 20.02.08	Výrobca 20.02.08 20.02.08
Profesionálne Systémy Trasy Káblových						800...

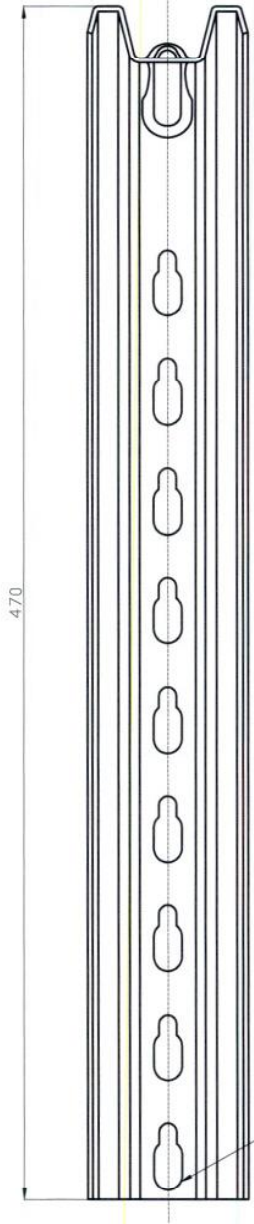
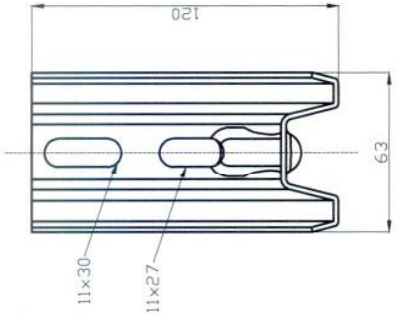

FIRES s.r.o.
POŽIARNA ODOLNOSŤ
FIRE RESISTANCE

Dokument č. **FIRE5-FR-191-10-10VE**
Document No.

Príloha č./Appendix No. **62**

Dátum/Date: **16.09.2010**
Podpis/Signature: *[Signature]*

	Projektant	Naziska G. Matuzewski	Docihytka wymiarów nietolerowanych	Ga tunek Nr normy półfabrykat (nr normy)	Masa [kg] ---	Podziałka 4:1	Format A4
	Rysował						
	Sprawdził	Data 04.06.10	Nazwa rysunku ---	Nazwa rysunku ---	Nr rysunku ---	Nr zmiany	Nr zmiany
Za twierdził	Podpis G. Matuzewski	Data 04.06.10	Nazwa rysunku ---	Nazwa rysunku ---	Nr rysunku ---	Nr zmiany	Nr zmiany



Profesjonalne Systemy
Tras Kablowych

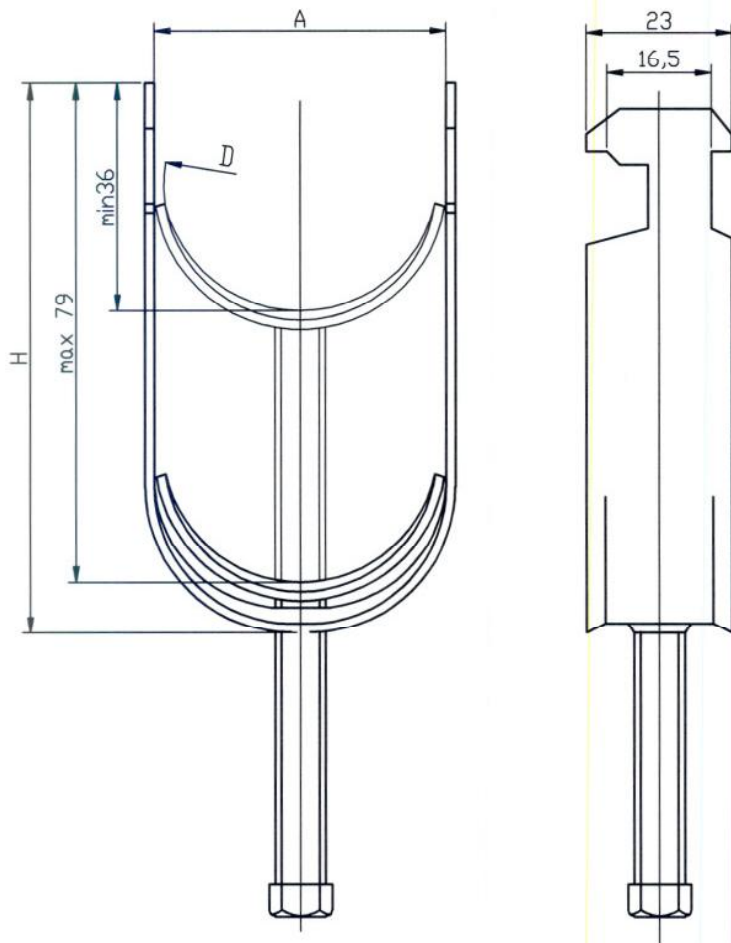

FIRES s.r.o. POŽIARNA ODOLNOSŤ FIRE RESISTANCE	Dátum/Date 16. 04. 2010
	Podpis/Signature
Dokument č. <i>FIRES-FR-141-10-TRAY</i> Document No.	
Príloha č./Appendix No. <i>03</i>	

UK01/58-64	66	103	64
UK01/46-52	54	97	52
UK01/40-46	48	86	46
UK01/34-40	42	78	40
UK01/28-34	36	71	34
UK01/22-28	30	61	28
UK01/16-22	24	57	22
SYMBOL	A	H	ØD

	Udchytka (výmiarů) nietolerovaných	Materiál Gatunek Nr normy półfabrykat (nr normy)	Masa [kg] -----	Podziałka 1:1	Format A4 Arkusz 1 Arkuszy 1
Rysował J.Jasiński	Nazwisko J.Kliczek	Podpis _____	Data 2004.12.29	Nr programu naszywanego ---	Nr ziany
Sprawdził J.Kliczek					
Profesjonalne Systemy Tras Kablowych					

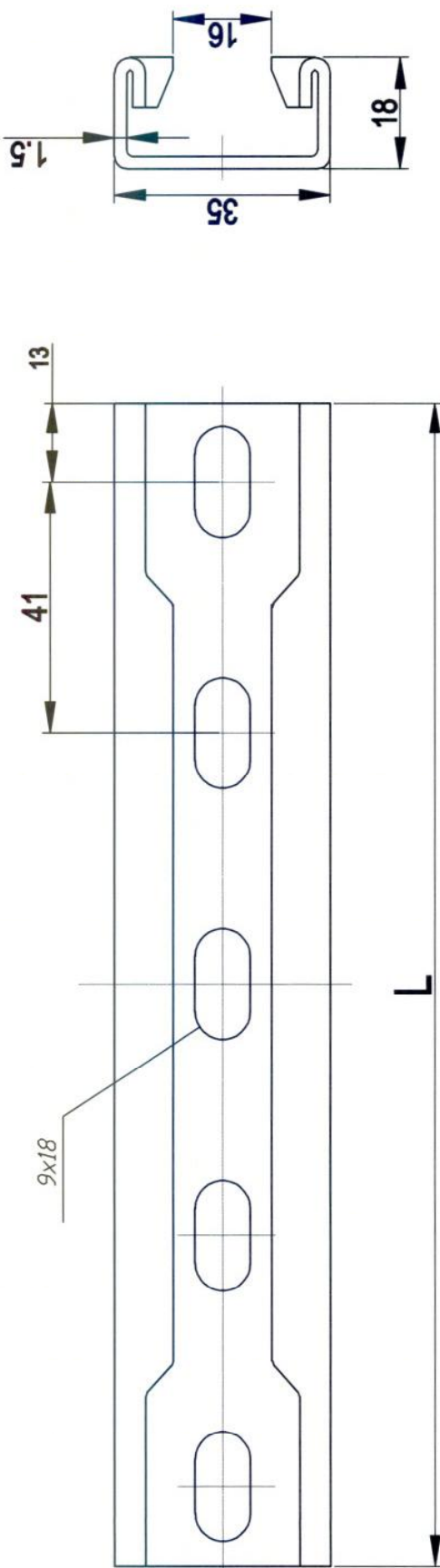

LP.	Nazwa wyrobu	Symbol	Długość L (mm)	Masa (kg)/szt.	Materiał	Nr katalogowy
8.	Szczebel	SDOP 1000	990	1,30		
7.	Szczebel	SDOP 800	790	1,04		
6.	Szczebel	SDOP 600	590	0,78		
5.	Szczebel	SDOP 500	490	0,65		
4.	Szczebel	SDOP 400	390	0,52		
3.	Szczebel	SDOP 300	290	0,39		
2.	Szczebel	SDOP 200	190	0,26		
1.	Szczebel	SDOP 100	90	0,13		

Długość L (mm)	990	Masa (kg)/szt.	1,30	Materiał		Nr katalogowy	
	790		1,04				
Symbol	SDOP 1000	Długość L (mm)	990	Masa (kg)/szt.	1,30	Materiał	
Nazwa wyrobu	Szczebel	Symbol	SDOP 1000	Długość L (mm)	990	Masa (kg)/szt.	1,30
Długość L (mm)	990	Symbol	SDOP 1000	Długość L (mm)	990	Masa (kg)/szt.	1,30
Masa (kg)/szt.	1,30	Symbol	SDOP 1000	Długość L (mm)	990	Masa (kg)/szt.	1,30
Materiał		Symbol	SDOP 1000	Długość L (mm)	990	Masa (kg)/szt.	1,30
Nr katalogowy		Symbol	SDOP 1000	Długość L (mm)	990	Masa (kg)/szt.	1,30

FIRES S.I.O.
 POŻIARNA ODOLNOŚĆ
 FIRE RESISTANCE

Dokument č. *FIRES-FR-111-10-ANNE*
 Document No. *FIRES-FR-111-10-ANNE*

Priloha č./Appendix No. *G5*

Dátum/Date
16.04.2020

Podpis/Signature
[Signature]

Projektował
 Rysował
 Sprawdził
 Zatwierdził

P. Okniński

Data
23.04.08



SZCZEBEL SDOP

Profesjonalne Systemy
 Tras Kablowych

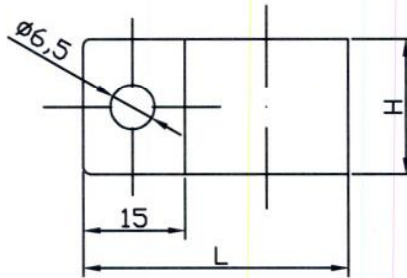
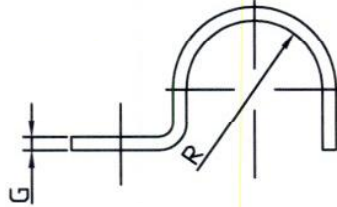
BAKS



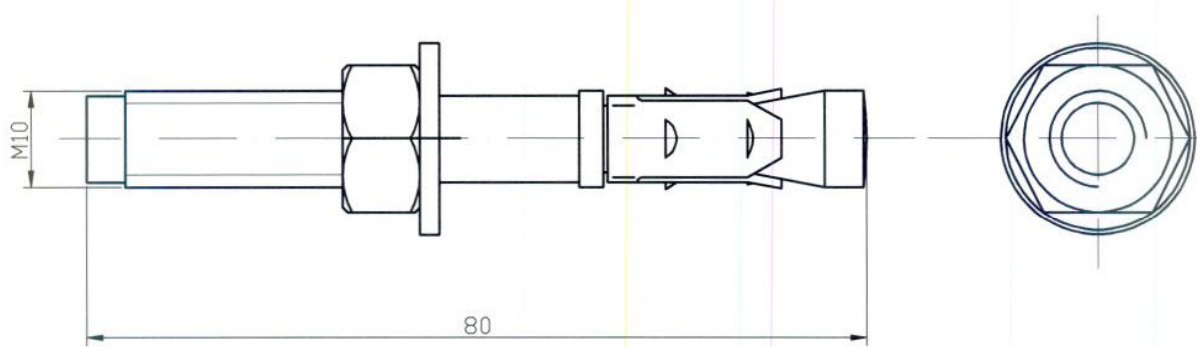

20	Uchwyt kabla	UDF 43	405543	21,5	60,0	20,0	2,0
19	Uchwyt kabla	UDF 40	405540	20,0	57,0	20,0	2,0
18	Uchwyt kabla	UDF 37	405537	18,5	54,0	20,0	2,0
17	Uchwyt kabla	UDF 34	405534	17,0	51,0	20,0	2,0
16	Uchwyt kabla	UDF 31	405531	15,5	48,0	20,0	2,0
15	Uchwyt kabla	UDF 28	405528	14,0	45,0	20,0	2,0
14	Uchwyt kabla	UDF 25	405525	12,5	44,0	20,0	2,0
13	Uchwyt kabla	UDF 22	405522	11,0	41,0	14,0	2,0
12	Uchwyt kabla	UDF 20	405520	10,0	39,0	14,0	2,0
11	Uchwyt kabla	UDF 18	405518	9,0	37,0	14,0	2,0
10	Uchwyt kabla	UDF 16	405516	8,0	35,0	14,0	2,0
9	Uchwyt kabla	UDF 15	405515	7,5	34,0	14,0	2,0
8	Uchwyt kabla	UDF 14	405514	7,0	33,0	14,0	1,2
7	Uchwyt kabla	UDF 12	405512	6,0	30,0	14,0	1,2
6	Uchwyt kabla	UDF 10	405510	5,0	28,0	14,0	1,2
5	Uchwyt kabla	UDF 9	405509	4,5	27,0	14,0	1,2
4	Uchwyt kabla	UDF 8	405508	4,0	26,0	14,0	1,2
3	Uchwyt kabla	UDF 7	405507	3,5	25,0	14,0	1,2
2	Uchwyt kabla	UDF 6	405506	3,0	24,0	14,0	1,2
1	Uchwyt kabla	UDF 5	405505	2,5	23,0	14,0	1,2
LP	Nazwa wyrobu	Symbol	Nr Katalogowy	R [mm]	L [mm]	H [mm]	G [mm]

	Dokchyłka wyniarów nietolerowanych	±0,5	Gatunek Nr normy półfabrykat (nr normy)	PN-EN 10327:2005 -----	Masa [kg] ---	Podziałka 1:1	Format A4
							Arkusze --
Projektował Rysował Sprawdził Zatwierdził	Nazwisko Jacek Grochowski Jakub Rudak Jacek Kliczek Jacek Kliczek	Podpis _____ _____ _____	Data 20.10.05 20.02.08 20.02.08 20.02.08	Nazwa rysunku UDF 5-43			Nr zmiany _____ _____ _____
 Profesjonalne Systemy Tras Kablowych				Nr rysunku 4055.....			

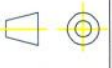

 FIRES s.r.o. POZIARNA ODOLNOST' FIRE RESISTANCE	Datum/Date 16. 09. 2010
	Podpis/Signature <i>Jan S</i>
Dokument č. Document No.	FIRES-12-144-10-12WE
Příloha č./Appendix No.	66

	Odchytka wymiarów nietolerowanych		Gatunek Stal cynkowana galwanicznie	Masa [kg]	Podziałka 1:1	Format A4	
			Nr normy			Arkusz	
Projektował J.GROCHOWSKI	Nazwisko J.Grochowski T.WŁODARCZYK J.KLICZEK	Podpis	półfabrykat (nr normy)			Arkuszy	
Rysował J.Grochowski			Data 20.10.05	Nazwa rysunku PSROM10x80			
Sprawdził T.WŁODARCZYK			Data 20.10.05				
Zatwierdził J.KLICZEK			Data 20.10.05				
	Profesjonalne Systemy Tras Kablowych		Nr rysunku 804100			Nr zmiany	

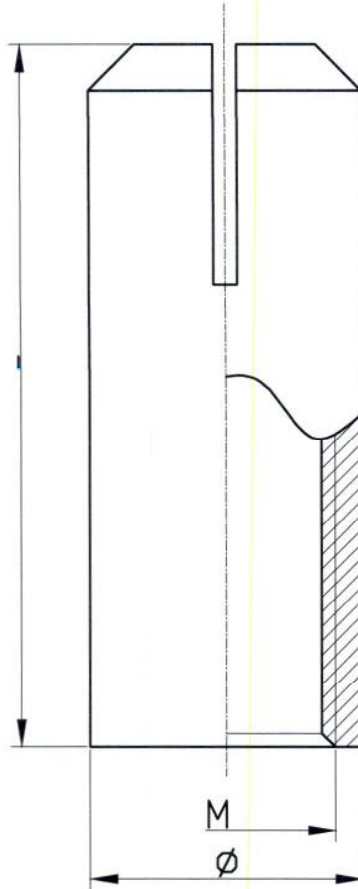

FIRES S.I.O. POZIARNA ODOLNOSĆ FIRE RESISTANCE	Dátum/Date 16.09.2010
	 Podpis/Signature
Dokument č. / Document No. <i>FIRES-FR-111-10-1111</i>	
Příloha č./Appendix No. <i>61</i>	

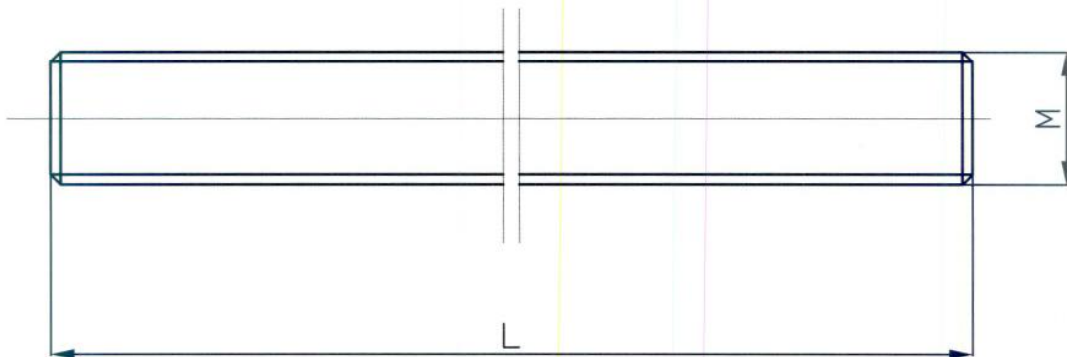

TRSDM10	12	M10	40
TRSDM8	10	M8	30
NAZWA	Ø	M	L

Odchyłka wymiarów nietolerowanych			Gatunek Nr normy pólfabrykat (nr normy)	Masa [kg] ---	Podziałka 4:1	Format A4
						Arkusz
Projektował	G. Matuszewski	Podpis	20.10.05	Nazwa rysunku <i>TRSDM...</i>		
Rysował	G. Matuszewski		20.10.05			
Sprawdził	--		20.10.05			
Zatwierdził	--		20.10.05			
Profesjonalne Systemy Tras Kablowych			Nr rysunku	---		Nr zmiany



 FIRES s.r.o. POŽIARNA ODOLNOSŤ FIRE RESISTANCE	Dátum/Date 16.09.2010
	Podpis/Signature <i>[Signature]</i>
	Dokument č./Document No. <i>FIRES-FR-141-10-ANNE</i>
Príloha č./Appendix No. <i>68</i>	

SYMBOL	L (mm)
PGM6/2	2000
PGM8/2	2000
PGM10/2	2000

	Odchytka vynárův nietolerovaných		Materiál	Gatunek 5,8	Masa (kg) ---	Podzialka ---	Format A4 Arkusz 1 Arkuszy 1						
				Nr normy ----- półfabrykat (nr normy)									
Projektował	Nazwisko M.Stawikowski	Podpis M.Stawikowski	Data 20.10.05	Nazwa rysunku Pręt gwintowany PGM...									
Rysował													
Sprawdził													
Zatwierdził													
				Nr programu maszynowego ---		Nr zmiany							
 Profesjonalne Systemy Tras Kablowych				Nr rysunku 7		<table border="1"> <tr><td></td><td></td></tr> <tr><td></td><td></td></tr> <tr><td></td><td></td></tr> </table>							