

TEST REPORT FIRES-FR-156-14-AUNE

**Cable bearing system BAKS with power and communication cables
of Fabryka Kabli ELPAR**

This is an electronic version of a test report which was made as a copy of test report officially issued in a paper form. The electronic version of a test report shall be used only for informative purposes. Any information listed in this test report is the property of the sponsor and shall not be used or published without written permission. Contents of this file may only be modified by the editor i.e. Testing laboratory FIRES s.r.o. Batizovce. Sponsor is allowed to publish this test report in parts only with written permission of the editor.



TEST REPORT

FIRES-FR-156-14-AUNE

Tested property: Function in fire
Test method: STN 92 0205: 2014 (ZP-27/2008, DIN 4102-12: 1998-11)
Type of test: Accredited
Date of issue: 28. 08. 2014

Name of the product: Cable bearing system BAKS with power and communication cables of Fabryka Kabli ELPAR

Manufacturer: BAKS Kazimierz Sielski, ul. Jagodne 5, 05 – 480 Karczew, Poland
producer of cable bearing system
Fabryka Kabli ELPAR Sp. z o.o., Ul. Laskowska 1, Parczew 21-200, Poland
producer of cables

Sponsor: BAKS Kazimierz Sielski, ul. Jagodne 5, 05 – 480 Karczew, Poland

Test carried out: Fires, s.r.o., Testing laboratory
Task No.: PR-14-0311
Specimens received: 14. 08. 2014
Date of the test: 21. 08. 2014

Technician responsible for the technical side of this report: Bc. Dávid Šubert

Number of pages: 49
Test reports: 5

Copy No.: 2

Distribution list:

- Copy No. 1 FIRES, s. r. o., Osloboditeľov 282, 059 35 Batizovce, Slovak Republic (electronic version)
- Copy No. 2 BAKS Kazimierz Sielski, ul. Jagodne 5, 05 - 480 Karczew, Poland (electronic version)
- Copy No. 3 Fabryka Kabli ELPAR Sp. z o.o., Ul. Laskowska 1, Parczew 21-200, Poland (electronic version)
- Copy No. 4 BAKS Kazimierz Sielski, ul. Jagodne 5, 05-480 Karczew, Poland
- Copy No. 5 Fabryka Kabli ELPAR Sp. z o.o., Ul. Laskowska 1, Parczew 21-200, Poland

This report includes accreditation mark SNAS with additional mark ILAC-MRA. SNAS is signatory of ILAC-MRA, Mutual recognition agreement (of accreditation), which is focused on promoting of international acceptance of accredited laboratory data and reducing technical barriers to trade, such as the retesting of products on markets of signatories. More information about ILAC-MRA is on www.ilac.org. Signatories of ILAC-MRA are e.g. SNAS (Slovakia), CAI (Czech Republic), PCA (Poland), DakS (Germany) or BMWA (Austria). Up to date list of ILAC-MRA signatories is on www.ilac.org/documents/mra_signatories.pdf. FIRES, s.r.o. Batizovce is full member of EGOLF also, more information www.egolf.org.uk.



1. INTRODUCTION

This test report contains the results of test carried out by laboratory of FIRES, s.r.o., Testing laboratory in Batizovce, accredited by SNAS for testing. Certificate of accreditation No.: S-159. The purpose of the test was to gain information for product classification.

Test of function in fire was carried out according to standard STN 92 0205. Similar standards and regulations for tests of function in fire are ZP-27/2008 PAVUS and DIN 4102-12: 1998-11.

Deviations from standard at the test according to ZP-27/2008: This test was carried out according to standard STN 92 0205 and meets also all requirements of ZP-27/2008 and test results can be directly used for classification of tested cables according to ZP-27/2008. There are no deviations identified in process and carrying out of test.

Deviations from standard at the test according to DIN 4102-12: 1998-11: This test was carried out according to standard STN 92 0205 and meets requirements of DIN 4102-12: 1998-11. Basic deviation in process and carrying out of test between these standards is in measuring and in control of temperature in the test furnace. According to STN 92 0205, plate thermometers according to EN 1363-1 are used. According to DIN 4102-12: 1998-11, common thermocouples of construction which was used for this measurement till issue of EN 1363-1 are used. Measurement by plate thermometers acc. to EN 1363-1 can be considered as stricter method of temperature control in test furnace in compare with thermocouples used till issue of EN 1363-1. Therefore, it is possible to use results of test according to STN 92 0205 for classification of tested cables according to DIN 4102-12: 1998-11, but not conversely. Identified deviation results in stricter course of test and it can lead to reduced classification of tested cables what is accepted as enhanced security in practice.

Representatives from the sponsor's side witnessing the test:

Mr. Tomasz Żukowski	BAKS Kazimierz Sielski
Mr. Dawid Kozak	BAKS Kazimierz Sielski
Mr. Piotr Grabowski	Fabryka Kabli ELPAR Sp. z o.o.
Mr. Krzysztof Niedziela	Fabryka Kabli ELPAR Sp. z o.o.
Mr. Zbigniew Waszczuk	Fabryka Kabli ELPAR Sp. z o.o.

test directed by	Ing. Marek Gorlický
test carried out by	Bc. Dávid Šubert
operator	Miroslav Hudák

2. MEASURING EQUIPMENT

Identification number	Measuring equipment	Note
F 90 004	Vertical test furnace for fire resistance testing	-
F 69 010	PLC system for data acquisition and control TECOMAT TC 700	-
F 40 017	Control and communication software to PLC TECOMAT TC 700	-
F 40 018	SW Reliance	-
F 40 019	Visual and calculating software to PLC TECOMAT TC 700	-
F 40 020	Driver Tecomat – Reliance (SW)	-
F 69 009	PLC system for data acquisition and climate control TECOMAT TC 604	-
F 60 001 - F 60 009	Sensors of temperature and relative air humidity	climatic conditions measuring
F 71 008, F 71 009	Transducer of differential pressure (-50 to + 150) Pa	pressure inside the test furnace



Identification number	Measuring equipment	Note
F 10 521 - F 10 528	Plate thermometers	temperature inside the test furnace, according to EN 1363-1
F 10 701	Sheathed thermocouple type K Ø 3 mm	ambient temperature
F 54 020	Digital calliper (0 to 200) mm	-
F 54 056	Racking meter	-
F 57 007	Digital stop-watch	-
F 96 015	Test signal panel	-

3. PREPARATION OF THE SPECIMENS

Testing laboratory didn't take off individual components of the specimens. Components take-off and its delivering to the testing laboratory were carried out by the test sponsor. Assembling of the supporting system into the test furnace and mounting of cables and weights into the supporting system was carried out by workers of BAKS Kazimierz Sielski and Fabryka Kabli ELPAR Sp. z o.o. under supervision of laboratory technician.

4. PREPARATION OF THE TEST

4.1 DESCRIPTION OF THE SPECIMENS STRUCTURE

Test specimen comprised from cable bearing system BAKS Kazimierz Sielski company – cable trays, ladders, mesh trays and clips with accessories (consoles, brackets, supports, hangers etc.) and power and communication halogen free cables of company Fabryka Kabli ELPAR Sp. z o.o..

Cables

Used cables by test:

Power cables:

NHXH 0,6/1kV 4x1,5RE mm ² E90	(14x)
NHXH 0,6/1kV 4x50RM mm ² E90	(14x)
NHXCH 0,6/1kV 4x1,5/1,5RE mm ² E90	(14x)
NHXCH 0,6/1kV 4x50/25RM mm ² E90	(14x)
(N)HXH 0,6/1kV 4x1,5RE mm ² E90	(4x)
(N)HXH 0,6/1kV 4x50RM mm ² E90	(2x)
(N)HXCH 0,6/1kV 4x1,5/1,5RE mm ² E90	(2x)
(N)HXCH 0,6/1kV 4x50/25RM mm ² E90	(12x)

Communication cables:

HDGs 300/500V 2x1 mm ² E90 PH90	(12x)
HTKSH FE180/PH90 240V 1x2x0,8mm	(14x)

The length of cables was 5,2 m and 4,0 m from that was exposed to fire.

Cable bearing systems were made of following constructions:

Suspension tracks No. 1 – 5

Tracks are made of three consoles (WPCB700 – tracks No. 1 and 2, WPCB1000 – tracks No. 3 – 5) fixed to ceiling by threaded rods (PG M10) in spacing of 1200 mm. Brackets (WWS/WWSO400) are fixed to consoles by screws (SM M10x30). Holders (UPW/UPWO) are fixed at the end of brackets with screws (SGK M8x14). Brackets are fixed through these holders by threaded rods (PG M10) with washer and nuts (M10) to ceiling by holders (USV/USOV). Holders (USV/USOV) are fixed to ceiling by threaded rods (PG M10). Standard supporting constructions.

Tracks No. 1, 3 and 4:

Cable trays (KCP/KCOP300H60, steel sheet thickness 1,5 mm) fixed together by two junctions (LPP/LPOPH60) and screws (SGK M6x12) on sides and by junction (BL/BLO300) and screws (SGK M6x12) on the bottom. Trays are fixed to brackets by screws (SGK M6x12) and loaded with 10kg.m^{-1} . Cables are fixed to trays by cable clips (UDF).

Tracks No. 2 and 5:

Cable ladders (DGOP400H60, steel sheet thickness 1,5 mm, spacing of transoms 150 mm) fixed together by two junctions (LDC/LDOCH60) and screws (SGK M8x14) on sides. Ladders are fixed to brackets by junctions (ZM/ZMO) and by screws (SGK M8x14) and loaded with 20kg.m^{-1} . Cables are fixed to ladders by cable clamps (UK1/UKO1 – according to cable cross-section).

Suspension tracks No. 6 – 11

Tracks are made of three consoles combined of assembling profile (CWP40H40/05; length of profile 500 mm) and two threaded rods (PG M10) fixed through the ceiling in spacing of 1500 mm.

Tracks No. 6 and 7:

Cable mesh trays (KDS/KDSO400H60, steel wire \varnothing 4,5 mm) fixed together by junctions (USS/USSO). Mesh trays are fixed to assembling profiles by junctions (ZS/ZSO) and loaded with 20kg.m^{-1} . Cables are fixed to trays by plastic stripes.

Tracks No. 8 and 10:

Cable trays (KGJ/KGOJ400H60, steel sheet thickness 0,9 mm) fixed together by screws (SGK M6x12). Trays are fixed to assembling profiles by screws (SGK M6x12) and loaded with 20kg.m^{-1} . Cables are fixed to trays by plastic stripes.

Tracks No. 9 and 11:

Cable ladders (DUOP400H60, steel sheet thickness 1,5 mm, spacing of transoms 300 mm) fixed together by two junctions (LDC/LDOCH60) and screws (SGK M8x14) on sides. Ladders are fixed to brackets by junctions (ZM/ZMO) and by screws (SGK M8x14) and loaded with 20kg.m^{-1} . Cables are fixed to ladders by cable clamps (UK1/UKO1 – according to cable cross-section).

Ceiling track No. 12

Track is made of assembling profiles SDOP400 fixed to ceiling by threaded rods (PG M8) in spacing of 300 mm. Cables are fixed to profiles by cable clamps (UK1/UKO1 – according to cable cross-section).

Ceiling track No. 13

Track is made of single cable clips (UDF) fixed to ceiling by expansion screws (MKR \varnothing 6 x 32) mm in spacing of 300 mm.

Wall track No. 14

Track is made of cable ladder (DGOP400H60) fixed to wall by hangers (UT) and threaded rods (PG M10). Length of cable ladder is 1,0 m and loaded with 60 kg. Installation without cables.

All bearing systems were from steel, galvanized according to the Sendzimir method PN-EN 10327:2005. Cable penetration through the wall of test furnace was sealed by mineral wool Rockwool. Loading with steel chain and line loads was used as the equivalent load.

More detailed information about construction of specimens is shown in the drawings which form an integral part of this test report. Drawings were delivered by sponsor.

All the information about technical specifications of used materials and semi-products, information about their type sign were delivered by sponsor. This information was not subject of the inspection of specimens. Parameters which were checked are quoted in paragraph 4.3.



4.2 DESCRIPTION OF SPECIMENS FIXATION

The test specimens were fixed on the ceiling of the test furnace which was created from aerated concrete panels with dimensions (4000 x 600 x 240) mm – 7 pieces. Ceiling panels were jointed by beam which provides balance deflection of the ceiling.

The type of specimen's fixation into the test furnace is shown in drawing documentation and it was selected by the sponsor.

4.3 INSPECTION OF SPECIMENS

Before and after the function in fire test, conformity of drawings and test specimens was checked. Specimens corresponded to the drawings which are part of this test report. Inspection of specimens consisted of visual review of the test specimens, used materials as well as size verification (number and cross sections of conductors, thickness, measurements of cables and trays) and also the way of specimens fixation to supporting construction was subject of inspection.

4.4 CLIMATIC CONDITIONING OF SPECIMENS

Test specimens were stored in the hall of testing laboratory under the following climatic conditions:

Ambient air temperature [°C]

mean	24,5
standard deviation	1,6

Relative air humidity [%]

mean	62,2
standard deviation	4,9

The humidity equilibrium state of test specimens was not determined. Test specimens did not comprise hygroscopic materials.

5. CARRYING OUT OF THE TEST

5.1 TEST GENERALLY

The test was carried out in horizontal test furnace with dimensions of (4000 x 3000 x 3000) mm (length x width x height).

5.2 CONDITIONS OF THE TEST

Conditions in the test furnace (temperature – standard temperature/time curve, pressure, content of O₂) as well as in the testing room (ambient temperature) corresponded to EN 1363-1 during the test. Detailed information is part of this test report, or in Quality records of the testing laboratory.

Values characterizing environment in the testing room directly before the test:

Relative air humidity [%]	Ambient air temperature [°C]
67,9	22,7

5.3 RESULTS OF THE TEST

Measured values of individual cables are stated in this test report.

During the test there was a gradual deflection of cable bearing system, but no failure or damage of tracks – even during cooling down of the tracks after termination of the test. Deflection of cable bearing system was not measured.



6. CLOSING

Evaluation of the test:

Specimen No.	Cables	Track No.	Time to first failure / interruption of conductor
1	2 cables NHXCH 0,6/1kV 4x50/25RM mm ² E90	11	79 minutes
2	2 cables (N)HXCH 0,6/1kV 4x50/25RM mm ² E90		42 minutes
3	2 cables NHXCH 0,6/1kV 4x1,5/1,5RE mm ² E90		65 minutes
4	2 cables (N)HXCH 0,6/1kV 4x50/25RM mm ² E90	10	71 minutes
5	2 cables NHXCH 0,6/1kV 4x50/25RM mm ² E90		90 minutes no failure / interruption
6	2 cables NHXCH 0,6/1kV 4x1,5/1,5RE mm ² E90		87 minutes
7	2 cables NHXCH 0,6/1kV 4x1,5/1,5RE mm ² E90	13	90 minutes no failure / interruption
8	2 cables NHXH 0,6/1kV 4x1,5RE mm ² E90		90 minutes no failure / interruption
9	2 cables (N)HXH 0,6/1kV 4x1,5RE mm ² E90	9	86 minutes
10	2 cables NHXH 0,6/1kV 4x50RM mm ² E90		43 minutes
11	2 cables NHXH 0,6/1kV 4x1,5RE mm ² E90		90 minutes no failure / interruption
12	2 cables NHXH 0,6/1kV 4x50RM mm ² E90	8	36 minutes
13	2 cables NHXH 0,6/1kV 4x1,5RE mm ² E90		90 minutes no failure / interruption
14	2 cables (N)HXCH 0,6/1kV 4x50/25RM mm ² E90	13	56 minutes
15	2 cables NHXCH 0,6/1kV 4x50/25RM mm ² E90		90 minutes no failure / interruption
16	2 cables NHXH 0,6/1kV 4x50RM mm ² E90		90 minutes no failure / interruption
17	2 cables (N)HXCH 0,6/1kV 4x50/25RM mm ² E90	7	44 minutes
18	2 cables NHXCH 0,6/1kV 4x50/25RM mm ² E90		83 minutes
19	2 cables NHXCH 0,6/1kV 4x1,5/1,5RE mm ² E90		73 minutes
20	2 cables (N)HXH 0,6/1kV 4x1,5RE mm ² E90	6	82 minutes
21	2 cables NHXH 0,6/1kV 4x50RM mm ² E90		90 minutes no failure / interruption
22	2 cables NHXH 0,6/1kV 4x1,5RE mm ² E90		51 minutes
23	2 cables NHXCH 0,6/1kV 4x50/25RM mm ² E90	5	85 minutes
24	2 cables NHXCH 0,6/1kV 4x1,5/1,5RE mm ² E90		90 minutes no failure / interruption
25	2 cables NHXCH 0,6/1kV 4x50/25RM mm ² E90	4	90 minutes no failure / interruption
26	cable NHXCH 0,6/1kV 4x1,5/1,5RE mm ² E90		79 minutes
27	cable NHXCH 0,6/1kV 4x1,5/1,5RE mm ² E90		75 minutes
28	cable (N)HXCH 0,6/1kV 4x50/25RM mm ² E90	3	90 minutes no failure / interruption
29	cable (N)HXCH 0,6/1kV 4x50/25RM mm ² E90		90 minutes no failure / interruption
30	cable (N)HXCH 0,6/1kV 4x1,5/1,5RE mm ² E90		89 minutes
31	cable (N)HXCH 0,6/1kV 4x1,5/1,5RE mm ² E90	12	90 minutes no failure / interruption
32	cable NHXCH 0,6/1kV 4x1,5/1,5RE mm ² E90		87 minutes
33	cable NHXCH 0,6/1kV 4x1,5/1,5RE mm ² E90		86 minutes
34	cable NHXH 0,6/1kV 4x1,5RE mm ² E90		87 minutes
35	cable NHXH 0,6/1kV 4x1,5RE mm ² E90		85 minutes
36	cable (N)HXH 0,6/1kV 4x50RM mm ² E90	2	90 minutes no failure / interruption
37	cable (N)HXH 0,6/1kV 4x50RM mm ² E90		90 minutes no failure / interruption
38	cable NHXH 0,6/1kV 4x50RM mm ² E90		90 minutes no failure / interruption
39	cable NHXH 0,6/1kV 4x50RM mm ² E90		90 minutes no failure / interruption
40	cable NHXH 0,6/1kV 4x1,5RE mm ² E90		52 minutes
41	cable NHXH 0,6/1kV 4x1,5RE mm ² E90		90 minutes no failure / interruption



Specimen No.	Cables	Track No.	Time to first failure / interruption of conductor
42	cable NHXH 0,6/1kV 4x50RM mm ² E90	1	90 minutes no failure / interruption
43	cable NHXH 0,6/1kV 4x50RM mm ² E90		90 minutes no failure / interruption
44	cable NHXH 0,6/1kV 4x1,5RE mm ² E90		90 minutes no failure / interruption
45	cable NHXH 0,6/1kV 4x1,5RE mm ² E90		90 minutes no failure / interruption
46	cable (N)HXCH 0,6/1kV 4x50/25RM mm ² E90	12	90 minutes no failure / interruption
47	cable (N)HXCH 0,6/1kV 4x50/25RM mm ² E90		90 minutes no failure / interruption
48	cable NHXCH 0,6/1kV 4x50/25RM mm ² E90		90 minutes no failure / interruption
49	cable NHXCH 0,6/1kV 4x50/25RM mm ² E90		90 minutes no failure / interruption
50	cable NHXH 0,6/1kV 4x50RM mm ² E90		90 minutes no failure / interruption
51	cable NHXH 0,6/1kV 4x50RM mm ² E90		90 minutes no failure / interruption
52	2 cables HTKSH FE180/PH90 240V 1x2x0,8mm	13	90 minutes no failure / interruption
53	2 cables HTKSH FE180/PH90 240V 1x2x0,8mm	9	26 minutes
54	2 cables HTKSH FE180/PH90 240V 1x2x0,8mm	8	40 minutes
55	2 cables HDGs 300/500V 2x1 mm ² E90 PH90		42 minutes
56	2 cables HDGs 300/500V 2x1 mm ² E90 PH90	7	9 minutes
57	2 cables HTKSH FE180/PH90 240V 1x2x0,8mm	6	40 minutes
58	2 cables HDGs 300/500V 2x1 mm ² E90 PH90	5	29 minutes
59	2 cables HDGs 300/500V 2x1 mm ² E90 PH90	3	43 minutes
60	2 cables HDGs 300/500V 2x1 mm ² E90 PH90	12	85 minutes
61	2 cables HTKSH FE180/PH90 240V 1x2x0,8mm		84 minutes
62	2 cables HTKSH FE180/PH90 240V 1x2x0,8mm	2	29 minutes
63	2 cables HTKSH FE180/PH90 240V 1x2x0,8mm	1	41 minutes
64	2 cables HDGs 300/500V 2x1 mm ² E90 PH90	9	35 minutes

The fire test was discontinued in 94th minute at the request of test sponsor.

Specimens S1 – S51 were tested by three-phase voltage supply 3 x 230/400V with bulbs 240V / 60 W.
Specimens S52 – S64 were tested by one-phase voltage supply 1 x 110V with LED diodes 3V /0,03W.

Circuit breakers with rating 3 A were used.



Measured values inside the test furnace

Time t [min]	Temperature [°C]											Deviation d _e [%]	Pressure p [Pa]
	Td1	Td2	Td3	Td4	Td5	Td6	Td7	Td8	Tave	Tn	To		
0	30,1	28,2	27,3	28,7	30,0	30,9	30,1	30,6	29,5	20,0	20,5	0,0	17,2
5	603,5	555,1	523,3	558,4	511,7	583,6	606,7	522,1	558,0	576,0	20,6	-2,6	19,4
10	695,4	671,4	670,3	668,8	661,6	712,6	723,0	675,1	684,8	678,0	20,6	-1,3	17,7
15	695,2	727,3	732,2	675,0	715,7	720,7	740,3	730,3	717,1	739,0	20,7	-1,6	17,9
20	746,0	794,9	810,0	740,7	760,7	767,2	798,5	776,2	774,3	781,0	20,7	-1,7	19,8
25	794,5	848,1	861,0	802,9	778,8	821,5	845,5	794,7	818,4	815,0	20,8	-1,3	19,2
30	817,4	871,3	892,7	828,6	803,4	848,7	878,2	819,8	845,0	842,0	20,8	-1,1	18,1
35	865,8	931,7	944,9	883,8	841,4	898,3	942,7	858,6	895,9	865,0	20,9	-0,6	18,4
40	913,4	897,0	898,8	876,5	891,9	927,0	930,8	910,1	905,7	885,0	20,9	-0,1	17,8
45	909,0	897,5	919,3	887,5	897,0	943,1	936,7	915,3	913,2	902,0	21,0	0,1	18,8
50	908,2	928,1	944,9	902,7	922,1	937,7	944,3	940,9	928,6	918,0	21,0	0,2	19,4
55	916,7	922,6	913,2	909,0	881,3	942,1	928,3	899,3	914,1	932,0	21,1	0,2	17,6
60	951,4	939,9	931,6	934,6	901,7	950,5	944,5	920,1	934,3	945,0	21,1	0,1	18,8
65	937,3	929,8	925,6	929,9	898,0	945,5	938,7	916,3	927,6	957,0	21,2	-0,1	19,5
70	951,3	941,8	935,1	941,1	919,6	955,9	949,6	938,4	941,6	968,0	21,2	-0,3	19,4
75	970,2	956,0	946,8	963,8	938,1	972,6	972,5	957,2	959,6	979,0	21,3	-0,4	18,5
80	985,2	974,2	975,5	977,9	989,0	990,3	988,0	1009,2	986,2	988,0	21,4	-0,5	18,1
85	995,1	988,1	993,0	989,8	980,6	1004,7	1001,5	1000,6	994,2	997,0	21,4	-0,5	19,5
90	1006,8	1000,7	1007,2	1002,3	996,2	1017,1	1015,0	1016,5	1007,7	1006,0	21,4	-0,5	18,1
91	1009,9	1003,8	1012,9	1005,9	999,6	1018,9	1019,1	1020,0	1011,3	1008,0	21,5	-0,5	18,5
92	1012,1	1004,7	1011,5	1007,4	1000,8	1022,0	1019,2	1021,2	1012,3	1009,0	21,4	-0,4	17,5
93	1014,3	1008,4	1015,1	1009,3	1002,8	1024,0	1021,7	1023,3	1014,9	1011,0	21,4	-0,4	19,9

- Tave** Average temperature in the test furnace calculated from plate thermometers
- Tn** Standard temperature in the test furnace laid down to test guideline
- To** Ambient temperature
- d_e** Deviation of the average temperature from the standard temperature calculated according to test guideline
- p** Pressure inside the test furnace measured under the ceiling of the test furnace

Layout of measuring points inside the test furnace:

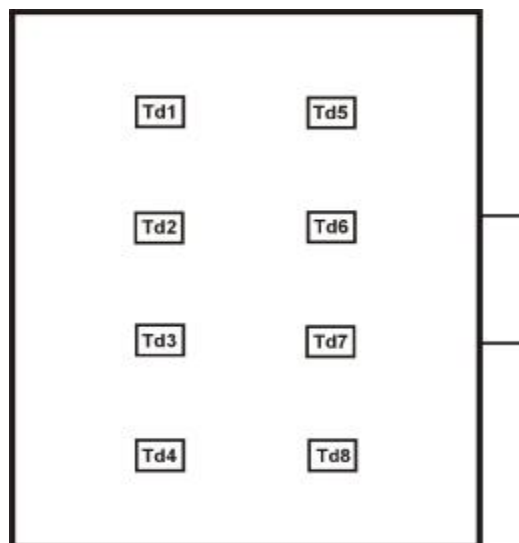



Measured values inside the test furnace /graph

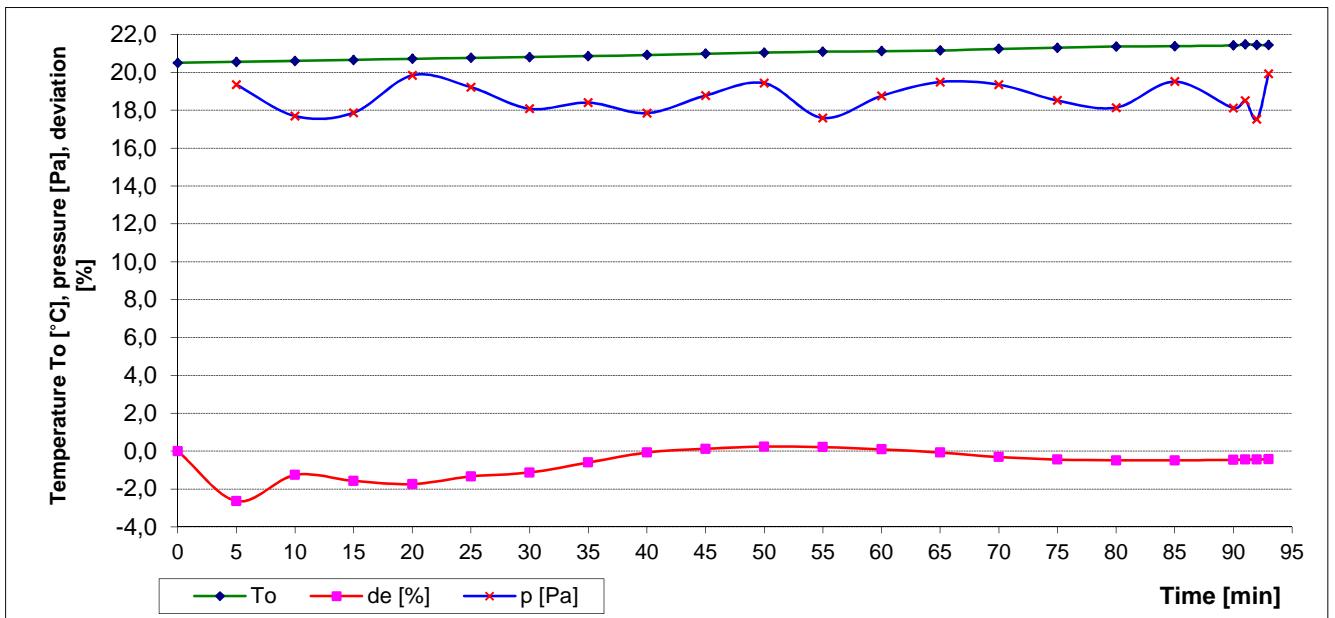
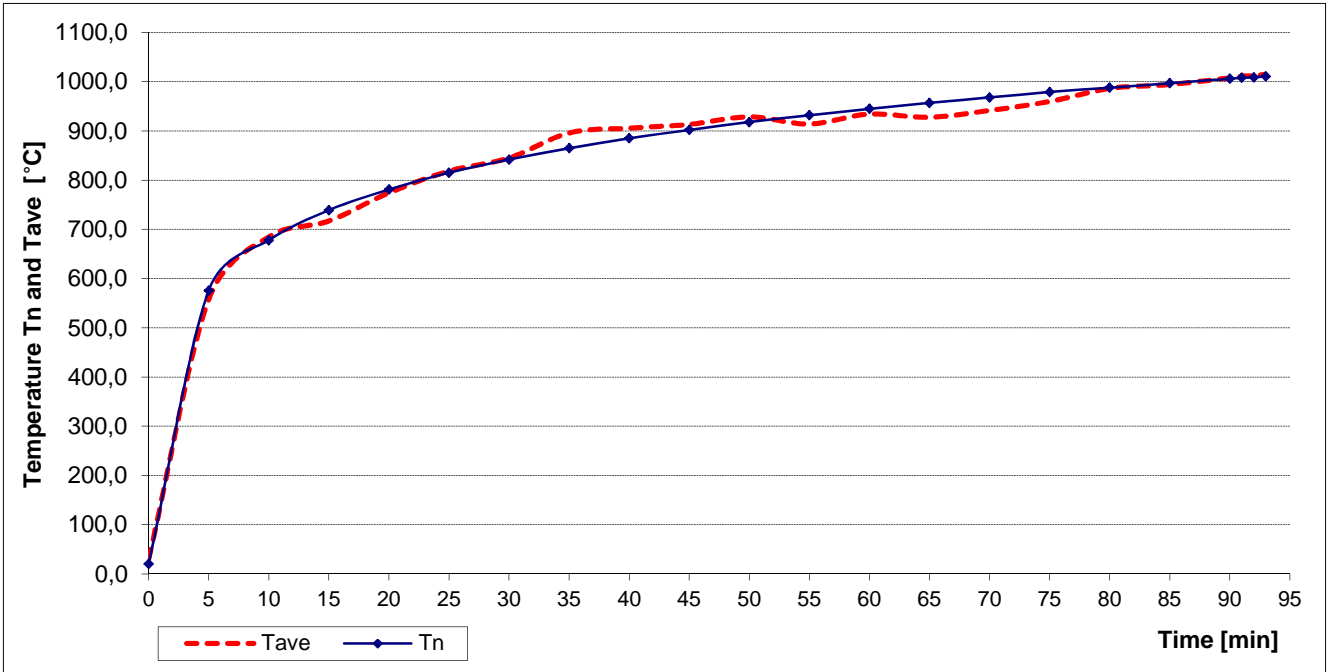
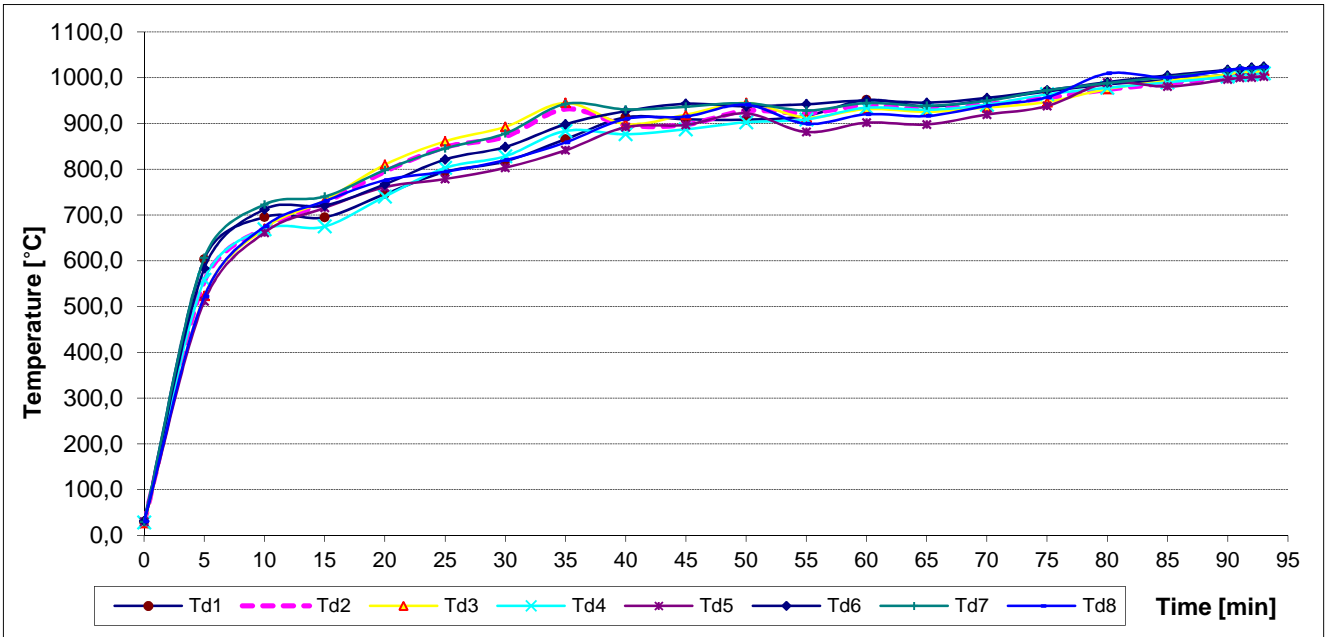

Measured time of tested specimens from S1 to S10 - power cables

Specimen	Bulbs	Time to permanent failure / interruption [min:s]
S1	1-L1	79:49
	2-L2	x
	3-L3	x
	4-PEN	x
S2	5-L1	42:09
	6-L2	x
	7-L3	x
	8-PEN	x
S3	9-L1	65:16
	10-L2	x
	11-L3	65:16
	12-PEN	x
S4	13-L1	x
	14-L2	71:45
	15-L3	x
	16-PEN	x
S5	17-L1	no failure / interruption
	18-L2	no failure / interruption
	19-L3	no failure / interruption
	20-PEN	no failure / interruption
S6	21-L1	87:44
	22-L2	x
	23-L3	x
	24-PEN	x
S7	25-L1	no failure / interruption
	26-L2	no failure / interruption
	27-L3	no failure / interruption
	28-PEN	no failure / interruption
S8	29-L1	no failure / interruption
	30-L2	no failure / interruption
	31-L3	no failure / interruption
	32-PEN	no failure / interruption
S9	33-L1	x
	34-L2	86:57
	35-L3	86:57
	36-PEN	x
S10	37-L1	43:48
	38-L2	43:48
	39-L3	x
	40-PEN	x

Specimen No.	Cables
1	2 cables NHXCH 0,6/1kV 4x50/25RM mm ² E90
2	2 cables (N)HXCH 0,6/1kV 4x50/25RM mm ² E90
3	2 cables NHXCH 0,6/1kV 4x1,5/1,5RE mm ² E90
4	2 cables (N)HXCH 0,6/1kV 4x50/25RM mm ² E90
5	2 cables NHXCH 0,6/1kV 4x50/25RM mm ² E90
6	2 cables NHXCH 0,6/1kV 4x1,5/1,5RE mm ² E90
7	2 cables NHXCH 0,6/1kV 4x1,5/1,5RE mm ² E90
8	2 cables NHXH 0,6/1kV 4x1,5RE mm ² E90
9	2 cables (N)HXH 0,6/1kV 4x1,5RE mm ² E90
10	2 cables NHXH 0,6/1kV 4x50RM mm ² E90

- x Conductor was turned off manually after permanent interruption / failure of other conductors in the cable
 Power cables were tested by three-phase voltage supply 3 x 230/400V with bulbs 240V / 60 W.
 Circuit breakers with rating 3 A were used.



Measured time of tested specimens from S11 to S20 - power cables

Specimen	Bulbs	Time to permanent failure / interruption [min:s]
S11	41-L1	no failure / interruption
	42-L2	no failure / interruption
	43-L3	no failure / interruption
	44-PEN	no failure / interruption
S12	45-L1	36:08
	46-L2	x
	47-L3	x
	48-PEN	x
S13	49-L1	no failure / interruption
	50-L2	no failure / interruption
	51-L3	no failure / interruption
	52-PEN	no failure / interruption
S14	53-L1	56:53
	54-L2	x
	55-L3	x
	56-PEN	x
S15	57-L1	no failure / interruption
	58-L2	no failure / interruption
	59-L3	no failure / interruption
	60-PEN	no failure / interruption
S16	61-L1	no failure / interruption
	62-L2	no failure / interruption
	63-L3	no failure / interruption
	64-PEN	no failure / interruption
S17	65-L1	x
	66-L2	44:19
	67-L3	x
	68-PEN	x
S18	69-L1	83:07
	70-L2	x
	71-L3	x
	72-PEN	x
S19	73-L1	x
	74-L2	73:17
	75-L3	73:17
	76-PEN	x
S20	77-L1	82:55
	78-L2	x
	79-L3	x
	80-PEN	x

Specimen No.	Cables
11	2 cables NHXH 0,6/1kV 4x1,5RE mm ² E90
12	2 cables NHXH 0,6/1kV 4x50RM mm ² E90
13	2 cables NHXH 0,6/1kV 4x1,5RE mm ² E90
14	2 cables (N)HXCH 0,6/1kV 4x50/25RM mm ² E90
15	2 cables NHXCH 0,6/1kV 4x50/25RM mm ² E90
16	2 cables NHXH 0,6/1kV 4x50RM mm ² E90
17	2 cables (N)HXCH 0,6/1kV 4x50/25RM mm ² E90
18	2 cables NHXCH 0,6/1kV 4x50/25RM mm ² E90
19	2 cables NHXCH 0,6/1kV 4x1,5/1,5RE mm ² E90
20	2 cables (N)HXH 0,6/1kV 4x1,5RE mm ² E90

- x Conductor was turned off manually after permanent interruption / failure of other conductors in the cable
Power cables were tested by three-phase voltage supply 3 x 230/400V with bulbs 240V / 60 W.
Circuit breakers with rating 3 A were used.

Measured time of tested specimens from S21 to S30 - power cables

Specimen	Bulbs	Time to permanent failure / interruption [min:s]
S21	81-L1	no failure / interruption
	82-L2	no failure / interruption
	83-L3	no failure / interruption
	84-PEN	no failure / interruption
S22	85-L1	51:53
	86-L2	51:53
	87-L3	51:53
	88-PEN	x
S23	89-L1	x
	90-L2	x
	91-L3	85:11
	92-PEN	x
S24	93-L1	no failure / interruption
	94-L2	no failure / interruption
	95-L3	no failure / interruption
	96-PEN	no failure / interruption
S25	97-L1	no failure / interruption
	98-L2	no failure / interruption
	99-L3	no failure / interruption
	100-PEN	no failure / interruption
S26	101-L1	79:15
	102-L2	79:15
	103-L3	79:15
	104-PEN	x
S27	105-L1	75:56
	106-L2	x
	107-L3	x
	108-PEN	x
S28	109-L1	no failure / interruption
	110-L2	no failure / interruption
	111-L3	no failure / interruption
	112-PEN	no failure / interruption
S29	113-L1	no failure / interruption
	114-L2	no failure / interruption
	115-L3	no failure / interruption
	116-PEN	no failure / interruption
S30	117-L1	89:25
	118-L2	89:25
	119-L3	89:25
	120-PEN	x

Specimen No.	Cables
21	2 cables NHXH 0,6/1kV 4x50RM mm ² E90
22	2 cables NHXH 0,6/1kV 4x1,5RE mm ² E90
23	2 cables NHXCH 0,6/1kV 4x50/25RM mm ² E90
24	2 cables NHXCH 0,6/1kV 4x1,5/1,5RE mm ² E90
25	2 cables NHXCH 0,6/1kV 4x50/25RM mm ² E90
26	cable NHXCH 0,6/1kV 4x1,5/1,5RE mm ² E90
27	cable NHXCH 0,6/1kV 4x1,5/1,5RE mm ² E90
28	cable (N)HXCH 0,6/1kV 4x50/25RM mm ² E90
29	cable (N)HXCH 0,6/1kV 4x50/25RM mm ² E90
30	cable (N)HXCH 0,6/1kV 4x1,5/1,5RE mm ² E90

- x Conductor was turned off manually after permanent interruption / failure of other conductors in the cable
 Power cables were tested by three-phase voltage supply 3 x 230/400V with bulbs 240V / 60 W.
 Circuit breakers with rating 3 A were used.

Measured time of tested specimens from S31 to S40 - power cables

Specimen	Bulbs	Time to permanent failure / interruption [min:s]
S31	121-L1	no failure / interruption
	122-L2	no failure / interruption
	123-L3	no failure / interruption
	124-PEN	no failure / interruption
S32	125-L1	x
	126-L2	87:37
	127-L3	x
	128-PEN	x
S33	129-L1	86:46
	130-L2	86:46
	131-L3	x
	132-PEN	x
S34	133-L1	87:18
	134-L2	x
	135-L3	87:18
	136-PEN	x
S35	137-L1	85:29
	138-L2	85:29
	139-L3	x
	140-PEN	x
S36	141-L1	no failure / interruption
	142-L2	no failure / interruption
	143-L3	no failure / interruption
	144-PEN	no failure / interruption
S37	145-L1	no failure / interruption
	146-L2	no failure / interruption
	147-L3	no failure / interruption
	148-PEN	no failure / interruption
S38	149-L1	no failure / interruption
	150-L2	no failure / interruption
	151-L3	no failure / interruption
	152-PEN	no failure / interruption
S39	153-L1	no failure / interruption
	154-L2	no failure / interruption
	155-L3	no failure / interruption
	156-PEN	no failure / interruption
S40	157-L1	x
	158-L2	x
	159-L3	52:55
	160-PEN	x

Specimen No.	Cables
31	cable (N)HXCH 0,6/1kV 4x1,5/1,5RE mm ² E90
32	cable NHXCH 0,6/1kV 4x1,5/1,5RE mm ² E90
33	cable NHXCH 0,6/1kV 4x1,5/1,5RE mm ² E90
34	cable NHXH 0,6/1kV 4x1,5RE mm ² E90
35	cable NHXH 0,6/1kV 4x1,5RE mm ² E90
36	cable (N)HXH 0,6/1kV 4x50RM mm ² E90
37	cable (N)HXH 0,6/1kV 4x50RM mm ² E90
38	cable NHXH 0,6/1kV 4x50RM mm ² E90
39	cable NHXH 0,6/1kV 4x50RM mm ² E90
40	cable NHXH 0,6/1kV 4x1,5RE mm ² E90

- x Conductor was turned off manually after permanent interruption / failure of other conductors in the cable
 Power cables were tested by three-phase voltage supply 3 x 230/400V with bulbs 240V / 60 W.
 Circuit breakers with rating 3 A were used.

Measured time of tested specimens from S41 to S50 - power cables

Specimen	Bulbs	Time to permanent failure / interruption [min:s]
S41	161-L1	no failure / interruption
	162-L2	no failure / interruption
	163-L3	no failure / interruption
	164-PEN	no failure / interruption
S42	165-L1	no failure / interruption
	166-L2	no failure / interruption
	167-L3	no failure / interruption
	168-PEN	no failure / interruption
S43	169-L1	no failure / interruption
	170-L2	no failure / interruption
	171-L3	no failure / interruption
	172-PEN	no failure / interruption
S44	173-L1	no failure / interruption
	174-L2	no failure / interruption
	175-L3	no failure / interruption
	176-PEN	no failure / interruption
S45	177-L1	no failure / interruption
	178-L2	no failure / interruption
	179-L3	no failure / interruption
	180-PEN	no failure / interruption
S46	181-L1	no failure / interruption
	182-L2	no failure / interruption
	183-L3	no failure / interruption
	184-PEN	no failure / interruption
S47	185-L1	no failure / interruption
	186-L2	no failure / interruption
	187-L3	no failure / interruption
	188-PEN	no failure / interruption
S48	189-L1	no failure / interruption
	190-L2	no failure / interruption
	191-L3	no failure / interruption
	192-PEN	no failure / interruption
S49	193-L1	no failure / interruption
	194-L2	no failure / interruption
	195-L3	no failure / interruption
	196-PEN	no failure / interruption
S50	197-L1	no failure / interruption
	198-L2	no failure / interruption
	199-L3	no failure / interruption
	200-PEN	no failure / interruption

Specimen No.	Cables
41	cable NHXH 0,6/1kV 4x1,5RE mm ² E90
42	cable NHXH 0,6/1kV 4x50RM mm ² E90
43	cable NHXH 0,6/1kV 4x50RM mm ² E90
44	cable NHXH 0,6/1kV 4x1,5RE mm ² E90
45	cable NHXH 0,6/1kV 4x1,5RE mm ² E90
46	cable (N)HXCH 0,6/1kV 4x50/25RM mm ² E90
47	cable (N)HXCH 0,6/1kV 4x50/25RM mm ² E90
48	cable NHXCH 0,6/1kV 4x50/25RM mm ² E90
49	cable NHXCH 0,6/1kV 4x50/25RM mm ² E90
50	cable NHXH 0,6/1kV 4x50RM mm ² E90

- x Conductor was turned off manually after permanent interruption / failure of other conductors in the cable
Power cables were tested by three-phase voltage supply 3 x 230/400V with bulbs 240V / 60 W.
Circuit breakers with rating 3 A were used.

Measured time of tested specimen S51 - power cable

Specimen	Bulbs	Time to permanent failure / interruption [min:s]
S51	201-L1	no failure / interruption
	202-L2	no failure / interruption
	203-L3	no failure / interruption
	204-PEN	no failure / interruption

Specimen No.	Cables
51	cablE NHXH 0,6/1kV 4x50RM mm ² E90

Power cables were tested by three-phase voltage supply 3 x 230/400V with bulbs 240V / 60 W.
Circuit breakers with rating 3 A were used.

Measured time of tested specimen S52 to S61 - communication cables

Specimen	Bulbs	Time to permanent failure / interruption [min:s]
S52A	209-L	no failure / interruption
	210-PEN	no failure / interruption
S52B	211-L	no failure / interruption
	212-PEN	no failure / interruption
S53A	213-L	26:59
	214-PEN	-
S53B	215-L	33:26
	216-PEN	-
S54A	217-L	43:41
	218-PEN	-
S54B	219-L	40:21
	220-PEN	-
S55A	221-L	42:39
	222-PEN	-
S55B	223-L	42:06
	224-PEN	-
S56A	225-L	31:14
	226-PEN	-
S56B	227-L	9:19
	228-PEN	-
S57A	229-L	40:40
	230-PEN	-
S57B	231-L	41:21
	232-PEN	-
S58A	233-L	30:29
	234-PEN	-
S58B	235-L	29:09
	236-PEN	-
S59A	237-L	76:15
	238-PEN	-
S59B	239-L	43:53
	240-PEN	-
S60A	241-L	no failure / interruption
	242-PEN	no failure / interruption
S60B	243-L	85:04
	244-PEN	-
S61A	245-L	85:01
	246-PEN	-
S61B	247-L	84:35
	248-PEN	-

Specimen No.	Cables
52	2 cables HTKSH FE180/PH90 240V 1x2x0,8mm
53	2 cables HTKSH FE180/PH90 240V 1x2x0,8mm
54	2 cables HTKSH FE180/PH90 240V 1x2x0,8mm
55	2 cables HDGs 300/500V 2x1 mm ² E90 PH90
56	2 cables HDGs 300/500V 2x1 mm ² E90 PH90
57	2 cables HTKSH FE180/PH90 240V 1x2x0,8mm
58	2 cables HDGs 300/500V 2x1 mm ² E90 PH90
59	2 cables HDGs 300/500V 2x1 mm ² E90 PH90
60	2 cables HDGs 300/500V 2x1 mm ² E90 PH90
61	2 cables HTKSH FE180/PH90 240V 1x2x0,8mm

Signal cables were tested by three-phase voltage supply 1 x 110V with LED diods 3V / 0,03W.
Circuit breakers with rating 3 A were used.

Measured time of tested specimens from S62 to S64 - communication cables

Specimen	Bulbs	Time to permanent failure / interruption [min:s]
S62A	249-L	31:39
	250-PEN	-
S62B	251-L	29:37
	252-PEN	-
S63A	253-L	43:51
	254-PEN	-
S63B	255-L	41:03
	256-PEN	-
S64A	257-L	65:00
	258-PEN	-
S64B	259-L	35:07
	260-PEN	-

Specimen No.	Cables
62	2 cables HTKSH FE180/PH90 240V 1x2x0,8mm
63	2 cables HTKSH FE180/PH90 240V 1x2x0,8mm
64	2 cables HDGs 300/500V 2x1 mm ² E90 PH90

Signal cables were tested by three-phase voltage supply 1 x 110V with LED diods 3V / 0,03W.
Circuit breakers with rating 3 A were used.



PHOTOS



Photo taken before the test.



Photo taken before the test.



Photo taken before the test.



PHOTOS



Photo taken before the test.



Photo taken before the test.



Photo taken before the test.



PHOTOS



Photo taken after the test.



Photo taken after the test.



Photo taken after the test.



PHOTOS



Photo taken after the test.



Photo taken after the test.

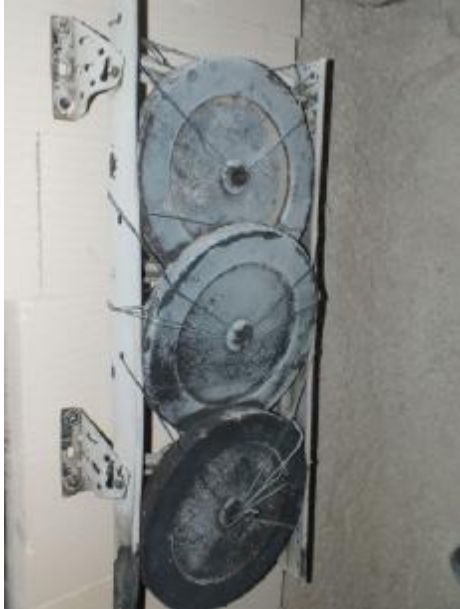

Photo taken after the test.



CABLES



Fabryka Kabli ELPAR Sp. z o.o.
21-200 PARCZEW, ul. Laskowska 1
tel. (+48 83) 355-03-38
fax (+48 83) 355-18-88
e-mail: info@elpar.pl

(N)HXH-J(O)

Fire resistant halogen free power cables

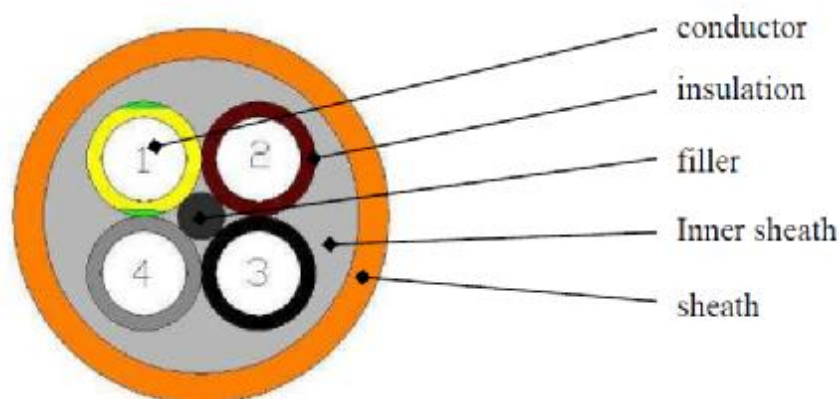
**TECHNICAL DATA:****CONSTRUCTION:**

Conductors:	Copper solid or stranded PN-EN 60228:2007
Insulation:	Cross-linked halogen free ceramic forming polymer compound acc. to DIN VDE 0266
Filler:	flame resistant, halogen free polymer compound
Inner sheath:	flame resistant, halogen free polymer compound
Sheath:	flame resistant, halogen free polymer compound acc. to DIN VDE 0276-604
Operating temperature:	-30°C to +70°C
Temperature of laying:	-5°C to +50°C
Bending radius multi core:	15 x D single core 12 x D multi core D- outer diameter
Nominal voltage:	0,6/1 k V
Voltage test:	4000 V; 50 Hz
Fire resistance:	E90
Behaviour in fire:	PN-EN 50226:2006; IEC 60332-3
Application:	Safety cables are used in all locations where a special protection fire and fire damage in necessary from human life and equipment and where strict safety regulations have to met and large emergency running time is necessary. They may be used indoor and outdoor, but not directly in earth and water. They are considered as protectively insulated.

Conductor cross-section	
n	mm ²
1+4	1,5+240
5+7	1,5+70
7+10	1,5+25
10+24	1,5+2,5

CABLES



Fabryka Kabli ELPAR Sp. z o.o.
21-200 PARCZEW, ul. Laskowska 1
tel. (+48 83) 355-03-38
fax (+48 83) 355-18-88
e-mail: info@elpar.pl

(N)HXCH-J(O)

Fire resistant halogen free power cables

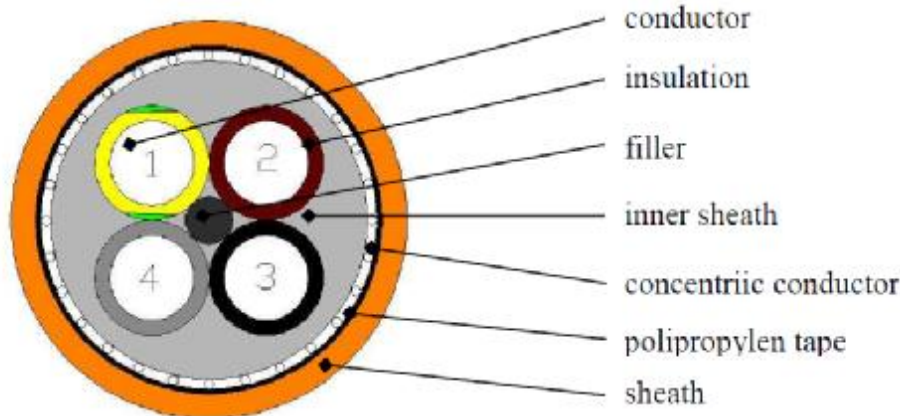
**TECHNICAL DATA:**

CONSTRUCTION:	
Conductors:	Copper solid or stranded PN-EN 60228:2007
Insulation:	Cross-linked halogen free ceramic forming polymer compound acc. to DIN VDE 0266
Filler:	flame resistant, halogen free polymer compound
Inner sheath:	flame resistant, halogen free polymer compound
Concentric conductor:	made of copper wires counter-wrapped
Polipropylen tape:	Polipropylen tape
Sheath:	flame resistant, halogen free polymer compound acc. to DIN VDE 0276-604
Operating temperature:	-30°C to +70°C
Temperature of laying:	-5°C to +50°C
Bending radius multi core:	15 x D single core 12 x D multi core D- outer diameter
Nominal voltage:	0,6/1 kV
Voltage test:	4000 V; 50 Hz
Fire resistance:	E90
Behaviour in fire:	PN-EN 50226:2006; IEC 60332-3
Application:	Safety cables are used in all locations where a special protection fire and fire damage in necessary from human life and equipment and where strict safety regulations have to met and large emergency running time is necessary. They may be used indoor and outdoor, but not directly in earth and water. They are considered as protectively insulated.

Conductor cross-section		
n	mm ²	
1+4	1,5/1,5~240/70	
5+7	1,5/1,5+4/4	
10+24	1,5/2,5+2,5/10	



CABLES



Fabryka Kabli ELPAR Sp. z o.o.
21-200 PARCZEW, ul. Laskowska 1
tel. (+48 83) 355-03-38
fax (+48 83) 355-18-88
e-mail: info@elpar.pl

NHXH-J(O)

Fire resistant halogen free power cables

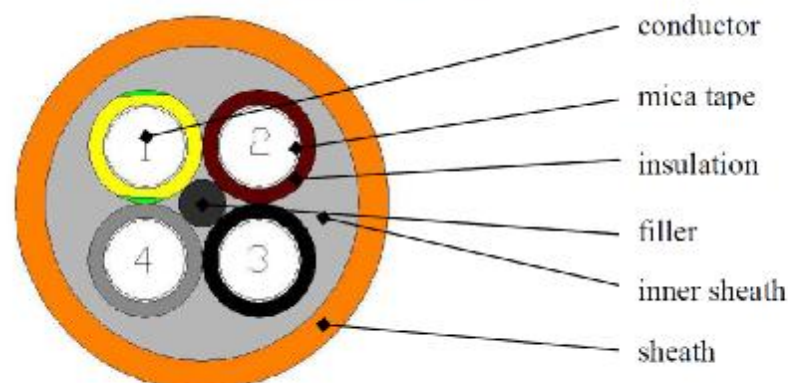

TECHNICAL DATA:

CONSTRUCTION:

Conductors:	copper solid or stranded PN-EN 60228:2007
Insulation:	mica tape and cross-linked halogen free forming polymer compound acc. to DIN VDE 026
Filler:	flame resistant, halogen free polymer compound
Inner sheath:	flame resistant, halogen free polymer compound
Sheath:	flame resistant, halogen free polymer compound acc. to DIN VDE 0276-604
Operating temperature:	-30°C to +70°C
Temperature of laying:	-5°C to +50°C
Bending radius multi core:	15 x D single core 12 x D multi core D- outer diameter
Nominal voltage:	0,6/1 kV
Voltage test:	4000 V; 50 Hz
Fire resistance:	E90
Behaviour in fire:	PN-EN 50226:2006; IEC 60332-3
Application:	Safety cables are used in all locations where a special protection fire and fire damage in necessary from human life and equipment and where strict safety regulations have to met and large emergency running time is necessary. They may be used indoor and outdoor, but not directly in earth and water. They are considered as protectively insulated.

Conductor cross-section	
n	mm ²
1+4	1,5+240
5+7	1,5+70
7+10	1,5+25
10+24	1,5+2,5



Fabryka Kabli ELPAR Sp. z o.o.
21-200 PARCZEW, ul. Laskowska 1
tel. (+48 83) 355-03-38
fax (+48 83) 355-18-88
e-mail: info@elpar.pl

NHXCH-J(O)

Fire resistant halogen free power cables

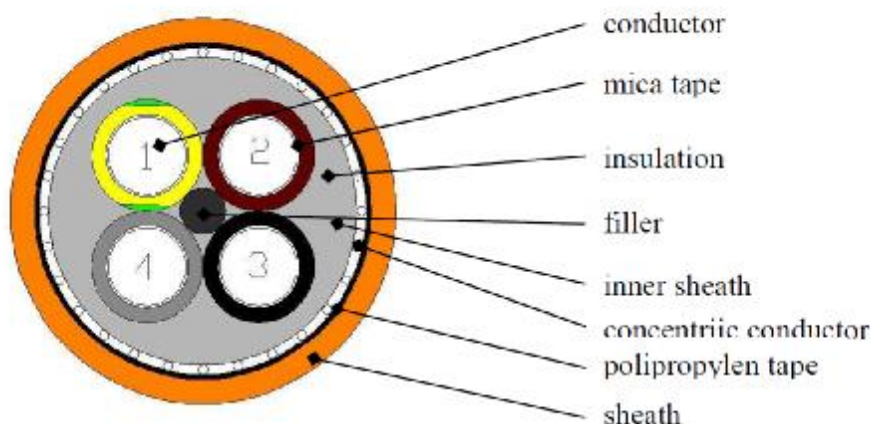

TECHNICAL DATA:

CONSTRUCTION:

Conductors:	copper solid or stranded PN-EN 60228:2007
Insulation:	mica tape and cross-linked halogen free forming polymer compound acc. to DIN VDE 0266
Filler:	flame resistant, halogen free polymer compound
Inner sheath:	flame resistant, halogen free polymer compound
Concentric conductor:	made of copper wires counter-wrapped
Polipropylen tape:	Polipropylen tape
Sheath:	flame resistant, halogen free polymer compound acc. to DIN VDE 0276-604
Operating temperature:	-30°C to +70°C
Temperature of laying:	-5°C to +50°C
Bending radius multi core:	15 x D single core 12 x D multi core D- outer diameter
Nominal voltage:	0,6/1 k V
Voltage test:	4000 V; 50 Hz
Fire resistance:	E90
Behaviour in fire:	PN-EN 50226:2008; IEC 60332-3
Application:	Safety cables are used in all locations where a special protection fire and fire damage in necessary from human life and equipment and where strict safety regulations have to met and large emergency running time is necessary. They may be used indoor and outdoor, but not directly in earth and water. They are considered as protectively insulated.

Conductor cross-section	
n	mm ²
1-4	1,5/1,5+240/70
5-7	1,5/1,5+4/4
10-24	1,5/2,5+2,5/10

HDGs(żo) 300/500V

FE 180/PH90

NORMA:
NF-ELPAR-02:2007

STANDARD:
NF-ELPAR-02:2007

KABLE BEZHALOGENOWE, DGNIOODPORNE
HALOGEN-FREE, FLAME-RESISTANT CABLES



ELPAR HDGs(żo) 300/500 3x(L5 mm²) PH90 CE

INFORMACJE TECHNICZNE	
Objaśnienia symboliki literowej kabla	HDGs(żo) PH90 - kabel elektroenergetyczny o żyłach miedzianych o izolacji z gumy silikonowej ceramizującej (Gs) i powłoce z tworzywa bezhalogenowego (H) z żyłą ochronną (żo) z funkcją PH90
Żyły	jednodrutowe miedziane kl. 1
Izolacja	mieszanka silikonowa ceramizująca
Powłoka	tworzywo bezhalogenowe
Kolory izolacji	- z żyłą ochronną (żo): 3-żyły zielono-żółta, niebieska, brązowa 4-żyły zielono-żółta, brązowa, czarna, szara 5-żyły: zielono-żółta, niebieska, brązowa, czarna, szara więcej niż 5 żył: w warstwie zewnętrznej zielono-żółta (żyła licznikowa), niebieska, (żyła kierunkowa) i pozostałe żyły - ta sama dowolna barwa z wyjątkiem zielono-żółtej, żółtej, brązowej i niebieskiej - w innych warstwach: brązowa (żyła licznikowa), niebieska (żyła kierunkowa), pozostałe żyły - ta sama dowolna barwa z wyjątkiem zielono-żółtej, brązowej i niebieskiej. - bez żyły ochronnej: 2-żyły niebieska, brązowa 3-żyły czarna, brązowa, szara 4-żyły niebieska, brązowa, czarna, szara 5-żyły: niebieska, brązowa, czarna, szara, czarna - więcej niż 5 żył - w każdej warstwie: brązowa, (żyła licznikowa), niebieska, (żyła kierunkowa) i pozostałe żyły - ta sama, dowolna barwa z wyjątkiem zielono-żółtej, brązowej i niebieskiej
Temperatura pracy	-25°C do +90°C
Napięcie znamionowe	300/500V
Zastosowanie	kable ognioodporne mają zastosowanie w miejscach, gdzie musi być zapewnione funkcjonowanie urządzeń podczas trwania pożaru, specjalne tworzywa i sposób montażu kabli zapewniają dopływ energii elektrycznej przez przynajmniej 90 min, a trwałość izolacji kabli wynosi 180 min. przy temp. 750°C, kable stosuje się w instalacjach oświetlenia awaryjnego, wyciągach dymu, systemach alarmowych, sygnalizacyjnych DSO, sygnalizacji pożaru i automatyce pożarniczej
Pakowanie	bębny lub krążki o długości 100 i 200 m oraz inne formy, zgodnie z życzeniem klienta

TECHNICAL INFORMATION	
Cable symbol explanation	HDGs(żo) PH90 - power cable with copper conductors and in ceramising silicone rubber insulation (Gs) and halogen-free plastic sheath (H) with protective conductor (żo) with PH90 function
Conductors	single-wire copper, class 1
Insulation	ceramising silicone mixture
Sheath	halogen-free plastics
Insulation colours	- with protective conductor (żo): 3-core: green and yellow, blue, brown 4-core: green and yellow, brown, black, grey 5-core: green and yellow, blue, brown, black, grey more than 5-core: in outer layer green and yellow (meter conductor), blue, (directional conductor) and remaining conductors - the same optional colour with the exception of: green and yellow, brown and blue - in other layers: brown (meter conductor) blue, (directional conductor), the remaining conductors - the same optional colour with the exception of: green and yellow, brown and blue - without protective conductor: 2-core: blue, brown 3-core: black, brown, grey 4-core: blue, brown, black, grey 5-core: blue, brown, black, grey, black - more than 5-core: in each layer: brown (meter conductor) blue, (directional conductor), the remaining conductors - the same optional colour with the exception of: green and yellow, brown and blue
Operating temperature	-25°C to +90°C
Nominal voltage	300/500V
Application	fire resistant cables are used in places where it is necessary that devices should operate during a fire, special materials and the way of cables installation ensure the supply of electrical power for at least 90 min., cables insulation resistance is 180 min. at temperatures of 750°C, cables are used in emergency lighting installations, smoke extractors, alarm systems, signalling DSO systems, fire alarms and fire automation
Packing	drums or coils of the length of 100, 200 m and others, according to customer's wishes



HDGs(żo) 300/500V

FE180/PH90

Liczba i przekrój znamionowy żył Number and nominal cross-section of conductors (n x mm ²)	Przybliżona średnica zewnętrzna kabla Approximate cable full diameter (mm)	Przybliżona masa kabla Approximate cable full diameter (kg/km)
2 x 1	5,7	47
2 x 1,5	6,5	62
2 x 2,5	8,1	97
2 x 4	9,0	131
3 x 1	6,0	63
3 x 1,5	7,0	83
3 x 2,5	8,7	130
3 x 4	9,9	183
4 x 1	6,8	82
4 x 1,5	8,1	113
4 x 2,5	9,7	170
4 x 4	10,8	234
5 x 1	7,7	105
5 x 1,5	8,9	140
5 x 2,5	10,7	211
5 x 4	11,9	292
7 x 1	8,4	133
7 x 1,5	9,9	183
7 x 2,5	11,7	272
10 x 1	10,9	191
10 x 1,5	12,6	255
10 x 2,5	15,6	404
12 x 1	11,3	220
12 x 1,5	13,1	296
12 x 2,5	16,2	468
16 x 1	12,6	281
16 x 1,5	15,2	402
16 x 2,5	18,6	629
20 x 1	14,6	364
20 x 1,5	17,5	515
20 x 2,5	20,7	768
24 x 1	16,2	430
24 x 1,5	19,4	607
24 x 2,5	23,6	942
30 x 1	17,7	543
30 x 1,5	20,5	730
30 x 2,5	24,9	1137
37 x 1	19,1	649
37 x 1,5	22,7	909
37 x 2,5	26,9	1369



HTKSHmika 240V

FE180/PH90

NORMA:
NF-ELPAR-14:2008

STANDARD:
NF-ELPAR-14:2008

TELEKOMUNIKACYJNE KABLE STACYJNE BEZHALOGENOWE, OGNIOODPORNE
LOCAL TELECOMMUNICATION HALOGE-FREE, FLAME-RESISTANT CABLES



ELPAR HTKSHmika FE180/PH90 240V 1x4x1,4 mm² CE

INFORMACJE TECHNICZNE		TECHNICAL INFORMATION	
Objaśnienia symboliki literowej kabla	HTKSHmika PH90 - telekomunikacyjny (T) kabel (K) stacyjny (S) odporny na działanie ognia o żyłach miedzianych jednodrutowych, o izolacji z taśmy mikowej i z tworzywa bezhalogenowego (H), nierozprzestrzeniającego płomienia o ograniczonym wydzieleniu dymu i gazów korozyjnych oraz o powłoce z tworzywa bezhalogenowego (H), z funkcją (PH)	Cable symbol explanation	HTKSHmika PH90 - telecommunication (T) cable (K) local (S) flame-resistant with copper single-wire conductor, in halogen-free micro insulation (H) made of flame-retardant plastics with limited emission of smoke and corrosion gases and in halogen-free sheath (H), with (PH) function
Żyła	jednodrutowa miedziana kl. 1	Conductor	copper single-wire, class 1
Izolacja	dwuwarstwowa, taśma mikowa + tworzywo bezhalogenowe	Insulation	double-layer micro tape + halogen-free plastics
Ośrodek	żyły skręcone w pary, a pary w ośrodek	Central core	conductors stranded into pairs, and pairs into a central core
Powłoka	tworzywo bezhalogenowe nierozprzestrzeniające płomienia, o ograniczonym wydzieleniu dymu oraz gazów toksycznych i korozyjnych	Sheath	halogen-free, flame-retardant plastics, with limited emission of smoke and toxic, corrosion gases
Kolory izolacji	zgodna z IEC 60189-2 + A1 + A2	Insulation colours	in compliance with IEC 60189-2 + A1 + A2
Temperatura pracy	-30°C do +70°C	Operating temperature	-30°C to +70°C
Napięcie znamionowe	240V	Nominal voltage	240V
Zastosowanie	przewody przeznaczone są do połączeń stałych urządzeń stacyjnych, telefonicznych, teletransmisyjnych, wykorzystywane są do układania w obszarach zagrożonych pożarem w obwodach sygnalizacji przeciwpożarowej DSO	Application	cables are intended for permanent connections in local, telephone, teletransmission devices, they are used for installations in the areas with a danger of fire, in fire-protection signalling DSO
Pakowanie	kręgi o długości 100 m oraz inne formy, zgodnie z życzeniem Klienta	Packing	coils of the length of 100 m and others, according to customer's wishes



CABLES

HTKSHmika 240V

FE180/PH90

Ilość par x średnica żyły Number of pairs x conductor diameter (mm)	Przybliżona średnica zewnętrzna kabla Approximate cable full diameter (mm)	Przybliżona masa kabla Approximate cable full diameter (kg/km)
1 x 2 x 0,8	6,63	51,97
1 x 4 x 0,8	7,22	60,39
2 x 2 x 0,8	8,41	79,69
3 x 2 x 0,8	9,50	96,52
4 x 2 x 0,8	9,80	101,97
5 x 2 x 0,8	10,89	118,8
1 x 2 x 1,0	7,32	63,36
2 x 2 x 1,0	10,39	94,05
3 x 2 x 1,0	10,89	145,53
1 x 2 x 1,4	9,99	119,71
2 x 2 x 1,4	11,58	135,63
1 x 2 x 1,8	10,28	128,87
1 x 2 x 2,3	11,52	172,86
1 x 2 x 2,8	12,75	222,21

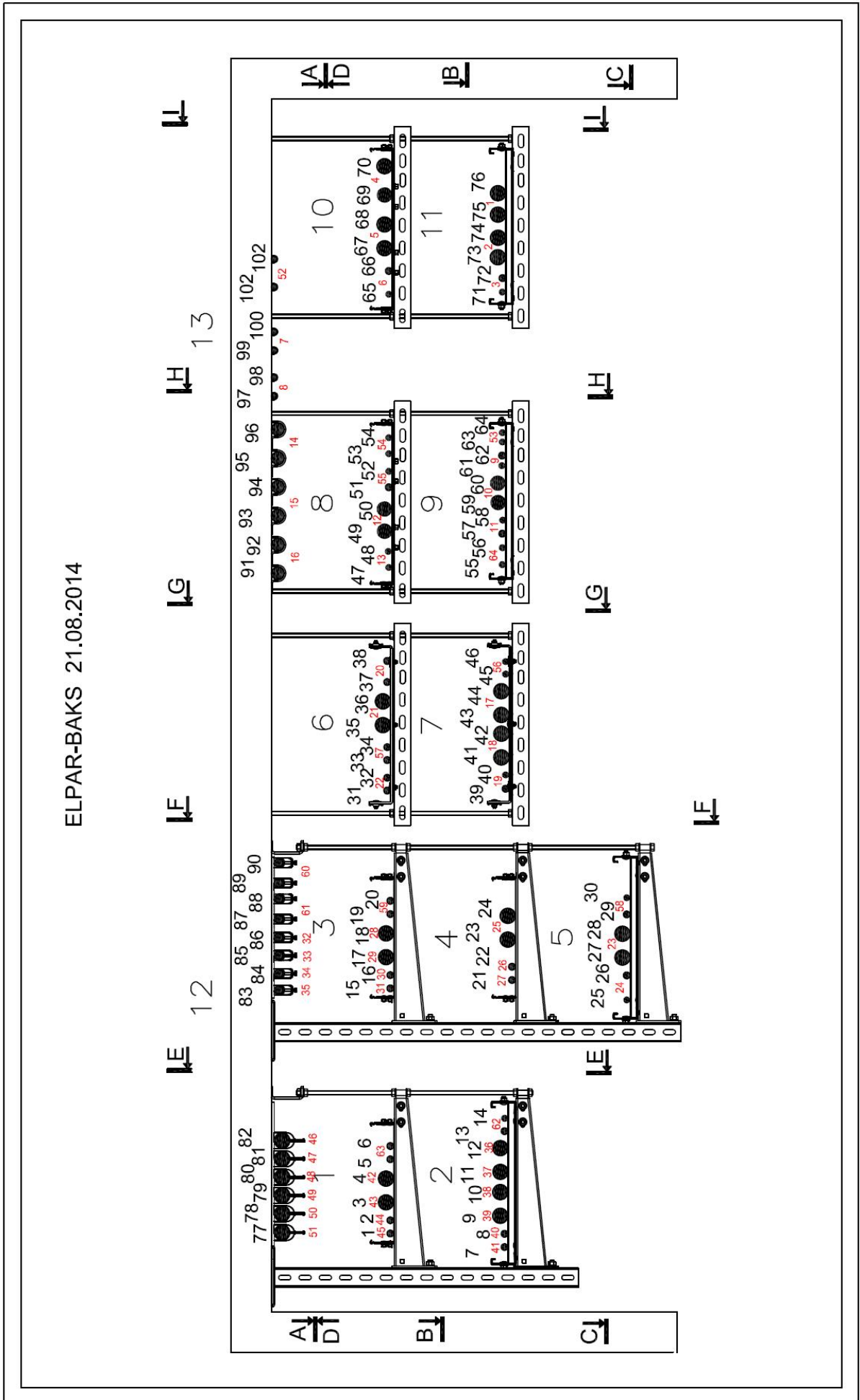



DRAWINGS

No	No FIRES	Cable type	Position	Description of construction		
1	45	NHXX 0,6/1kV 4x1,5RE mm ² E90	1	Cable trays KCP/KCOP300H60, 1.2 m/10kg.m ⁻¹ , steel thickness 1,5 mm. Construction: Consoles WPCB 700, brackets WWS/WWSO400, threaded rods PGM10, hangers USV/USOV		
2	44	NHXX 0,6/1kV 4x1,5RE mm ² E90				
3	43	NHXX 0,6/1kV 4x50RM mm ² E90				
4	42	NHXX 0,6/1kV 4x50RM mm ² E90				
5	63	HTKSH FE180/PH90 240V 1x2x0,8mm				
6		HTKSH FE180/PH90 240V 1x2x0,8mm				
7	41	NHXX 0,6/1kV 4x1,5RE mm ² E90	2	Cable ladders DGOP400H60, 1.2 m /20kg.m ⁻¹ , steel thickness 1,5 mm. Construction: Consoles WPCB700, brackets WWS/WWSO400, threaded rods PGM10, hangers USV/USOV		
8	40	NHXX 0,6/1kV 4x1,5RE mm ² E90				
9	39	NHXX 0,6/1kV 4x50RM mm ² E90				
10	38	NHXX 0,6/1kV 4x50RM mm ² E90				
11	37	(N)HXX 0,6/1kV 4x50RM mm ² E90				
12	36	(N)HXX 0,6/1kV 4x50RM mm ² E90				
13	62	HTKSH FE180/PH90 240V 1x2x0,8mm				
14		HTKSH FE180/PH90 240V 1x2x0,8mm				
15	31	(N)HXCH 0,6/1kV 4x1,5/1,5RE mm ² E90	3	Cable trays KCP/KCOP300H60, 1.2 m / 10kg.m ⁻¹ , steel thickness 1,5 mm. Construction: Consoles WPCB1000, brackets WWS/WWSO400, threaded rods PGM10, hangers USV/USOV		
16	30	(N)HXCH 0,6/1kV 4x1,5/1,5RE mm ² E90				
17	29	(N)HXCH 0,6/1kV 4x50/25RM mm ² E90				
18	28	(N)HXCH 0,6/1kV 4x50/25RM mm ² E90				
19	59	HDGs 300/500V 2x1 mm ² E90 PH90				
20		HDGs 300/500V 2x1 mm ² E90 PH90				
21	27	NHXCH 0,6/1kV 4x1,5/1,5RE mm ² E90	4	Cable trays KCP/KCOP300H60, 1.2 m /10kg.m ⁻¹ , steel thickness 1,5 mm. Construction: Consoles WPCB1000, brackets WWS/WWSO400, threaded rods PGM10, hangers USV/USOV		
22	26	NHXCH 0,6/1kV 4x1,5/1,5RE mm ² E90				
23	25	NHXCH 0,6/1kV 4x50/25RM mm ² E90				
24		NHXCH 0,6/1kV 4x50/25RM mm ² E90				
25	24	NHXCH 0,6/1kV 4x1,5/1,5RE mm ² E90	5	Cable ladders DGOP400H60, 1.2 m /20kg.m ⁻¹ , steel thickness 1,5 mm. Construction: Consoles WPCB1000, brackets WWS/WWSO400, threaded rods PGM10, hangers USV/USOV		
26		NHXCH 0,6/1kV 4x1,5/1,5RE mm ² E90				
27	23	NHXCH 0,6/1kV 4x50/25RM mm ² E90				
28		NHXCH 0,6/1kV 4x50/25RM mm ² E90				
29	58	HDGs 300/500V 2x1 mm ² E90 PH90				
30		HDGs 300/500V 2x1 mm ² E90 PH90				
31	22	NHXX 0,6/1kV 4x1,5RE mm ² E90			6	Cable mesh trays KDSO400H60, 1.5 m /20kg.m ⁻¹ , Construction: Assembling profiles CWP/CWOP40H40/05, threaded rods PG M10
32		NHXX 0,6/1kV 4x1,5RE mm ² E90				
33	57	HTKSH FE180/PH90 240V 1x2x0,8mm				
34		HTKSH FE180/PH90 240V 1x2x0,8mm				
35	21	NHXX 0,6/1kV 4x50RM mm ² E90				
36		NHXX 0,6/1kV 4x50RM mm ² E90				
37	20	(N)HXX 0,6/1kV 4x1,5RE mm ² E90				
38		(N)HXX 0,6/1kV 4x1,5RE mm ² E90				



DRAWINGS

No	No FIRES	Cable type	Position	Description of construction		
39	19	NHXCH 0,6/1kV 4x1,5/1,5RE mm ² E90	7	Cable mesh trays KDSO400H60, 1.5 m /20kg.m ⁻¹ , Construction: Assembling profiles CWP/CWOP40H40/05, threaded rods PG M10		
40		NHXCH 0,6/1kV 4x1,5/1,5RE mm ² E90				
41	18	NHXCH 0,6/1kV 4x50/25RM mm ² E90				
42		NHXCH 0,6/1kV 4x50/25RM mm ² E90				
43	17	(N)HXCH 0,6/1kV 4x50/25RM mm ² E90				
44		(N)HXCH 0,6/1kV 4x50/25RM mm ² E90				
45	56	HDGs 300/500V 2x1 mm ² E90 PH90				
46		HDGs 300/500V 2x1 mm ² E90 PH90				
47	13	NHXH 0,6/1kV 4x1,5RE mm ² E90			8	Cable trays KGJ/KGOJ400H60, 1.5 m /20kg.m ⁻¹ , steel thickness 0,9 mm. Construction: Assembling profiles CWP/CWOP40H40/05, threaded rods PG M10
48		NHXH 0,6/1kV 4x1,5RE mm ² E90				
49	12	NHXH 0,6/1kV 4x50RM mm ² E90				
50		NHXH 0,6/1kV 4x50RM mm ² E90				
51	55	HDGs 300/500V 2x1 mm ² E90 PH90				
52		HDGs 300/500V 2x1 mm ² E90 PH90				
53	54	HTKSH FE180/PH90 240V 1x2x0,8mm				
54		HTKSH FE180/PH90 240V 1x2x0,8mm				
55	64	HDGs 300/500V 2x1 mm ² E90 PH90	9	Cable ladders DUOP400H60, 1.5 m /20kg.m ⁻¹ , steel thickness 1,5 mm. Construction: Assembling profiles CWP/CWOP40H40/05, threaded rods PG M10		
56		HDGs 300/500V 2x1 mm ² E90 PH90				
57	11	NHXH 0,6/1kV 4x1,5RE mm ² E90				
58		NHXH 0,6/1kV 4x1,5RE mm ² E90				
59	10	NHXH 0,6/1kV 4x50RM mm ² E90				
60		NHXH 0,6/1kV 4x50RM mm ² E90				
61	9	(N)HXH 0,6/1kV 4x1,5RE mm ² E90				
62		(N)HXH 0,6/1kV 4x1,5RE mm ² E90				
63	53	HTKSH FE180/PH90 240V 1x2x0,8mm				
64		HTKSH FE180/PH90 240V 1x2x0,8mm				
65	6	NHXCH 0,6/1kV 4x1,5/1,5RE mm ² E90	10	Cable trays KGJ/KGOJ400H60, 1.5 m /20kg.m ⁻¹ , steel thickness 0,9 mm. Construction: Assembling profiles CWP/CWOP40H40/05, threaded rods PG M10		
66		NHXCH 0,6/1kV 4x1,5/1,5RE mm ² E90				
67	5	NHXCH 0,6/1kV 4x50/25RM mm ² E90				
68		NHXCH 0,6/1kV 4x50/25RM mm ² E90				
69	4	(N)HXCH 0,6/1kV 4x50/25RM mm ² E90				
70		(N)HXCH 0,6/1kV 4x50/25RM mm ² E90				
71	3	NHXCH 0,6/1kV 4x1,5/1,5RE mm ² E90			11	Cable ladders DUOP400H60, 1.5 m /20kg.m ⁻¹ , steel thickness 1,5 mm. Construction: Assembling profiles CWP/CWOP40H40/05, threaded rods PG M10
72		NHXCH 0,6/1kV 4x1,5/1,5RE mm ² E90				
73	2	(N)HXCH 0,6/1kV 4x50/25RM mm ² E90				
74		(N)HXCH 0,6/1kV 4x50/25RM mm ² E90				
75	1	NHXCH 0,6/1kV 4x50/25RM mm ² E90				
76		NHXCH 0,6/1kV 4x50/25RM mm ² E90				



DRAWINGS

No	No FIRES	Cable type	Position	Description of construction
77	51	NHXXH 0,6/1kV 4x50RM mm ² E90	12	Cable clamps UKO1, assembling profiles SDOP 400. Fixing to ceiling in spacing of 300 mm
78	50	NHXXH 0,6/1kV 4x50RM mm ² E90		
79	49	NHXCH 0,6/1kV 4x50/25RM mm ² E90		
80	48	NHXCH 0,6/1kV 4x50/25RM mm ² E90		
81	47	(N)HXCH 0,6/1kV 4x50/25RM mm ² E90		
82	46	(N)HXCH 0,6/1kV 4x50/25RM mm ² E90		
83	35	NHXXH 0,6/1kV 4x1,5RE mm ² E90		
84	34	NHXXH 0,6/1kV 4x1,5RE mm ² E90		
85	33	NHXCH 0,6/1kV 4x1,5/1,5RE mm ² E90		
86	32	NHXCH 0,6/1kV 4x1,5/1,5RE mm ² E90		
87	61	HTKSH FE180/PH90 240V 1x2x0,8mm		
88		HTKSH FE180/PH90 240V 1x2x0,8mm		
89	60	HDGs 300/500V 2x1 mm ² E90 PH90		
90		HDGs 300/500V 2x1 mm ² E90 PH90		
91	16	NHXXH 0,6/1kV 4x50RM mm ² E90	13	Cable clips UDF, spacing of 300mm
92		NHXXH 0,6/1kV 4x50RM mm ² E90		
93	15	NHXCH 0,6/1kV 4x50/25RM mm ² E90		
94		NHXCH 0,6/1kV 4x50/25RM mm ² E90		
95	14	(N)HXCH 0,6/1kV 4x50/25RM mm ² E90		
96		(N)HXCH 0,6/1kV 4x50/25RM mm ² E90		
97	8	NHXXH 0,6/1kV 4x1,5RE mm ² E90		
98		NHXXH 0,6/1kV 4x1,5RE mm ² E90		
99	7	NHXCH 0,6/1kV 4x1,5/1,5RE mm ² E90		
100		NHXCH 0,6/1kV 4x1,5/1,5RE mm ² E90		
101	52	HTKSH FE180/PH90 240V 1x2x0,8mm		
102		HTKSH FE180/PH90 240V 1x2x0,8mm		

Cable type	Diameter [mm]	Cable weight [g/m]	Amount
NHXXH 0,6/1kV 4x1,5RE mm ² E90	16	312	14
NHXXH 0,6/1kV 4x50RM mm ² E90	40	2998	14
NHXCH 0,6/1kV 4x1,5/1,5RE mm ² E90	18	365	14
NHXCH 0,6/1kV 4x50/25RM mm ² E90	42	3357	14
(N)HXH 0,6/1kV 4x1,5RE mm ² E90	16	345	4
(N)HXH 0,6/1kV 4x50RM mm ² E90	38	3135	2
(N)HXCH 0,6/1kV 4x1,5/1,5RE mm ² E90	18	410	2
(N)HXCH 0,6/1kV 4x50/25RM mm ² E90	42	3365	12
HDGs 300/500V 2x1 mm ² E90 PH90	8	63	12
HTKSH FE180/PH90 240V 1x2x0,8mm	8	44	14
TOTAL			102



ELPAR-BAKS 21.08.2014

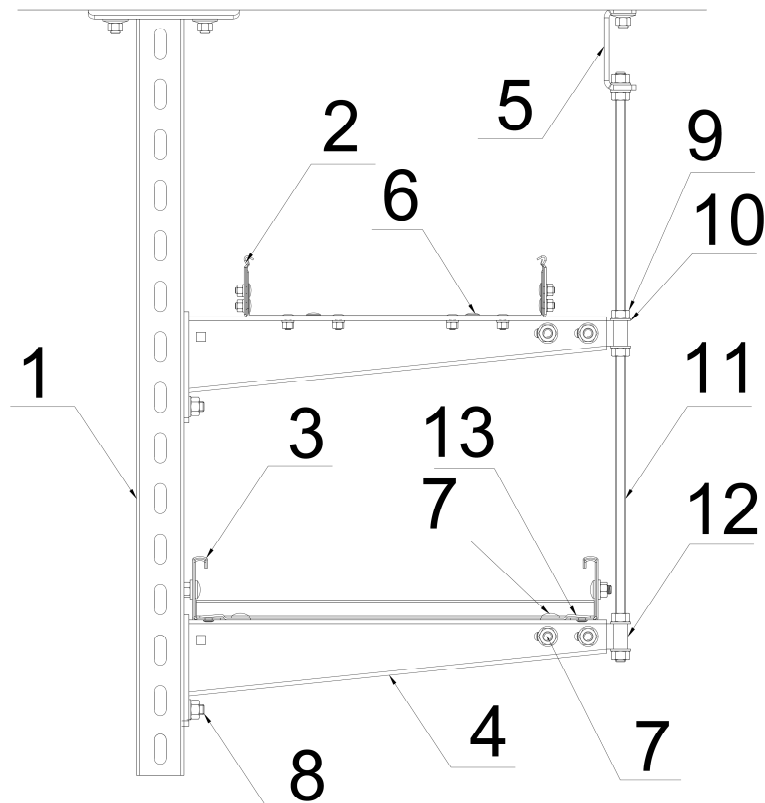

13	Zacisk mocujący	ZMO	2
12	Uchwyt	UPWO	2
11	Pręt gwintowany	PGM10 /...	1
10	Podkładka	PP 10	6
9	Nakrętka	NS M10	6
8	Śruba	SM M10x30	4
7	Śruba	SGK M8x14	6
6	Śruba	SGK M6x12	2
5	Uchwyt sufitowy	USOV	1
4	Wysięgnik	WWS400	2
3	Drabinka	DGOP400H60/3	1
2	Korytko	KCOP300H60/3	1
1	Wspornik sufitowy	WPCB700	1
L.p.	Nazwa	Symbol	Szt.



ELPAR-BAKS 21.08.2014

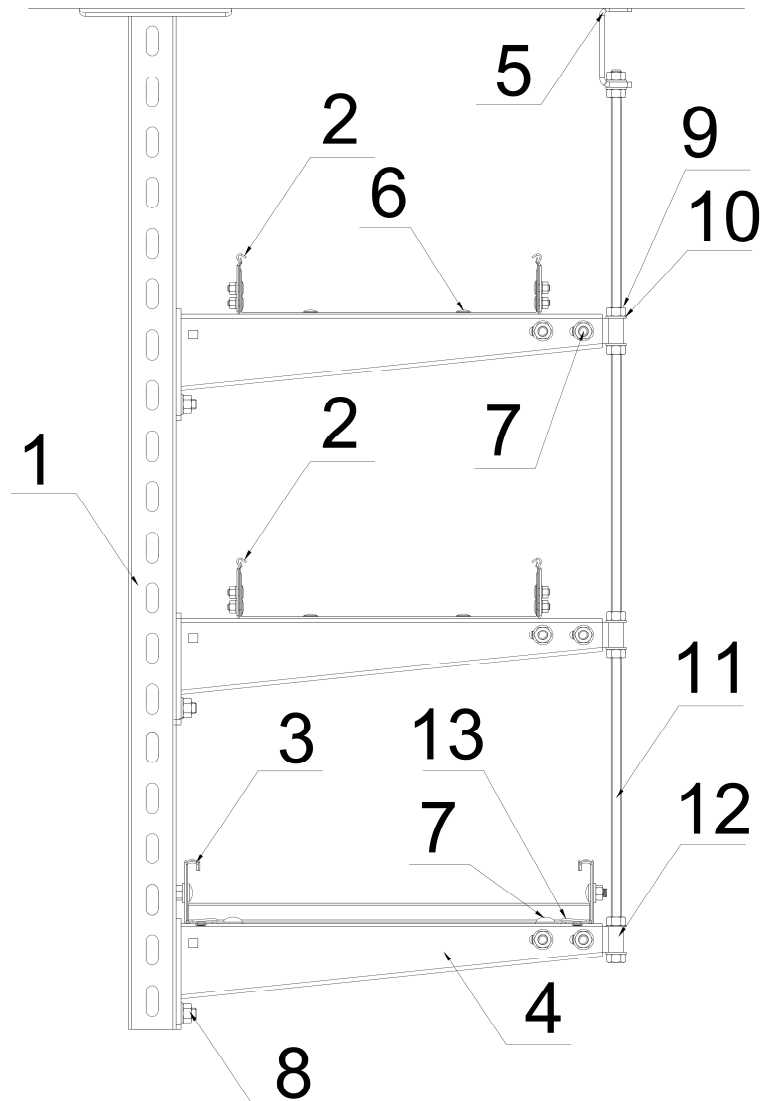

13	Zacisk mocujący	ZMO	2
12	Uchwyt	UPWO	3
11	Pręt gwintowany	PGM10 /...	1
10	Podkładka	PP 10	8
9	Nakrętka	NS M10	8
8	Śruba	SM M10x30	6
7	Śruba	SGK M8x14	8
6	Śruba	SGK M6x12	4
5	Uchwyt sufitowy	USOV	1
4	Wysięgnik	WWS400	3
3	Drabinka	DGOP400H60/3	1
2	Korytko	KCOP300H60/3	2
1	Wspornik sufitowy	WPCB1000	1
Lp.	Nazwa	Symbol	Szt.



ELPAR-BAKS 21.08.2014

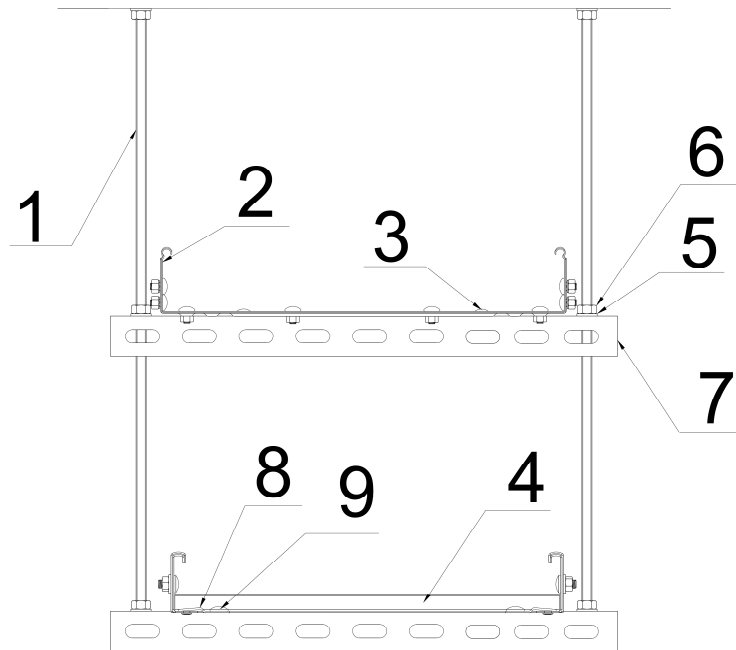

9	Śruba	NS M8x14	4
8	Zacisk mocujący	ZM/ZMO	2
7	Ceownik	CWP/CWOP40H40 /05	2
6	Nakrętka	NS M10	12
5	Podkładka	PP 10	12
4	Drabinka	DUOP400H60 /3	1
3	Śruba	NS M6x12	8
2	Korytko	KGJ/KGOJ400H60	1
1	Pręt gwintowany	PGM10 /...	2
L.p.	Nazwa	Symbol	Szt.



ELPAR-BAKS 21.08.2014

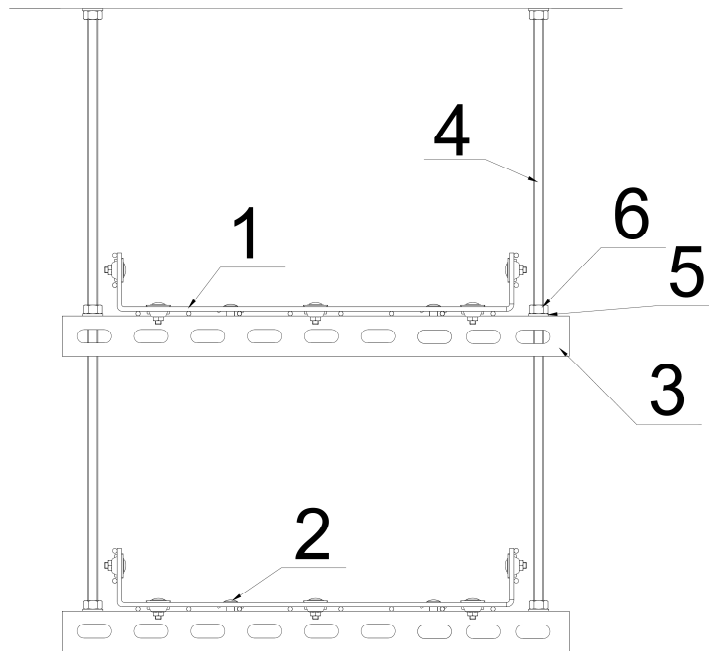

6	Nakrętka	NS M10	12
5	Podkładka	PP 10	12
4	Pręt gwintowany	PGM10 /...	2
3	Ceownik	CWP/CWOP40H40 /05	2
2	Zacisk śrubowy	ZS/ZSO	4
1	Koryto siatkowe	KDS/KDSO400H60	2
L.p.	Nazwa	Symbol	Szt.



ELPAR-BAKS 21.08.2014

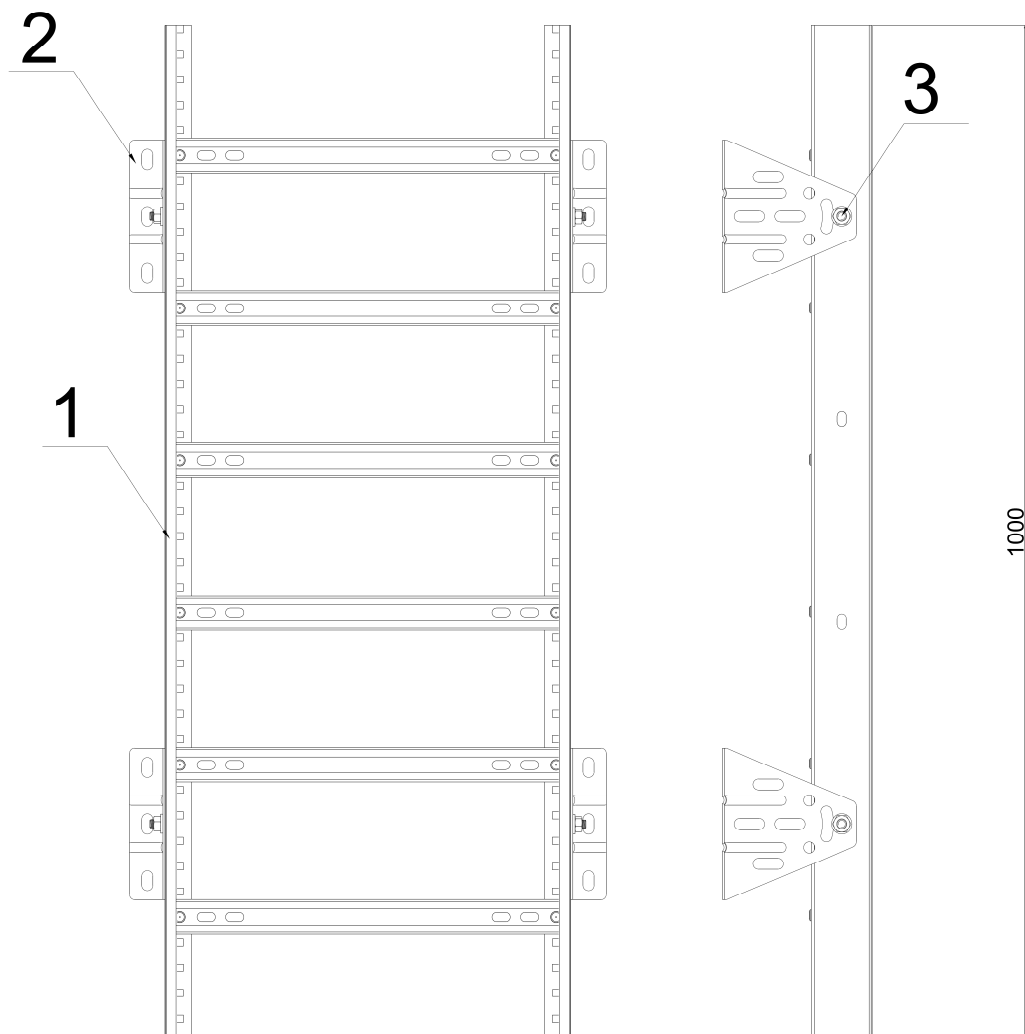

3	Śruba	SGK M8x14	4
2	Uchwyt trójkątny	UT	4
1	Drabinka	DGOP400H60	1
L.p.	Nazwa	Symbol	Szt.



A-A

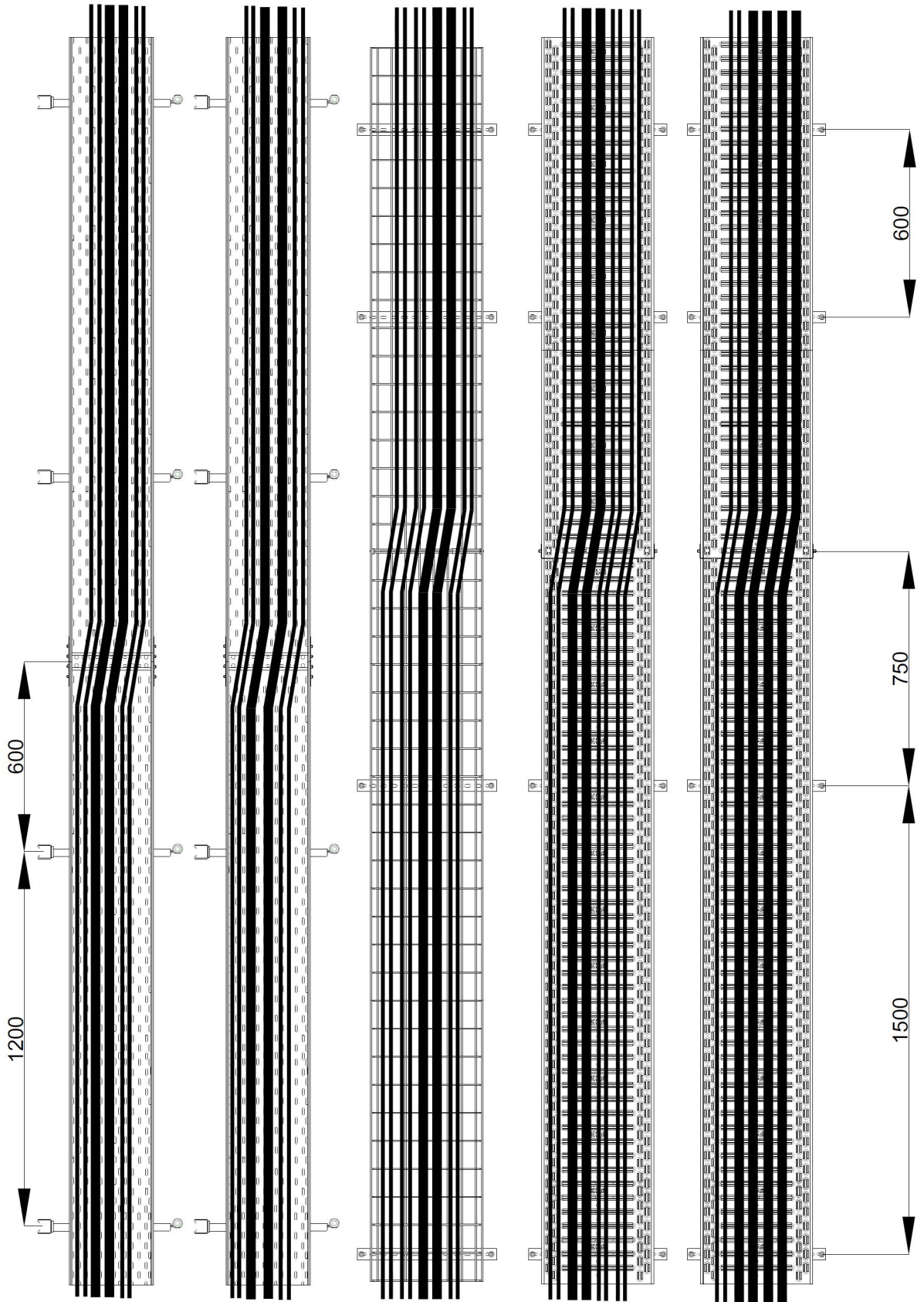

ELPAR-BAKS 21.08.2014



B-B

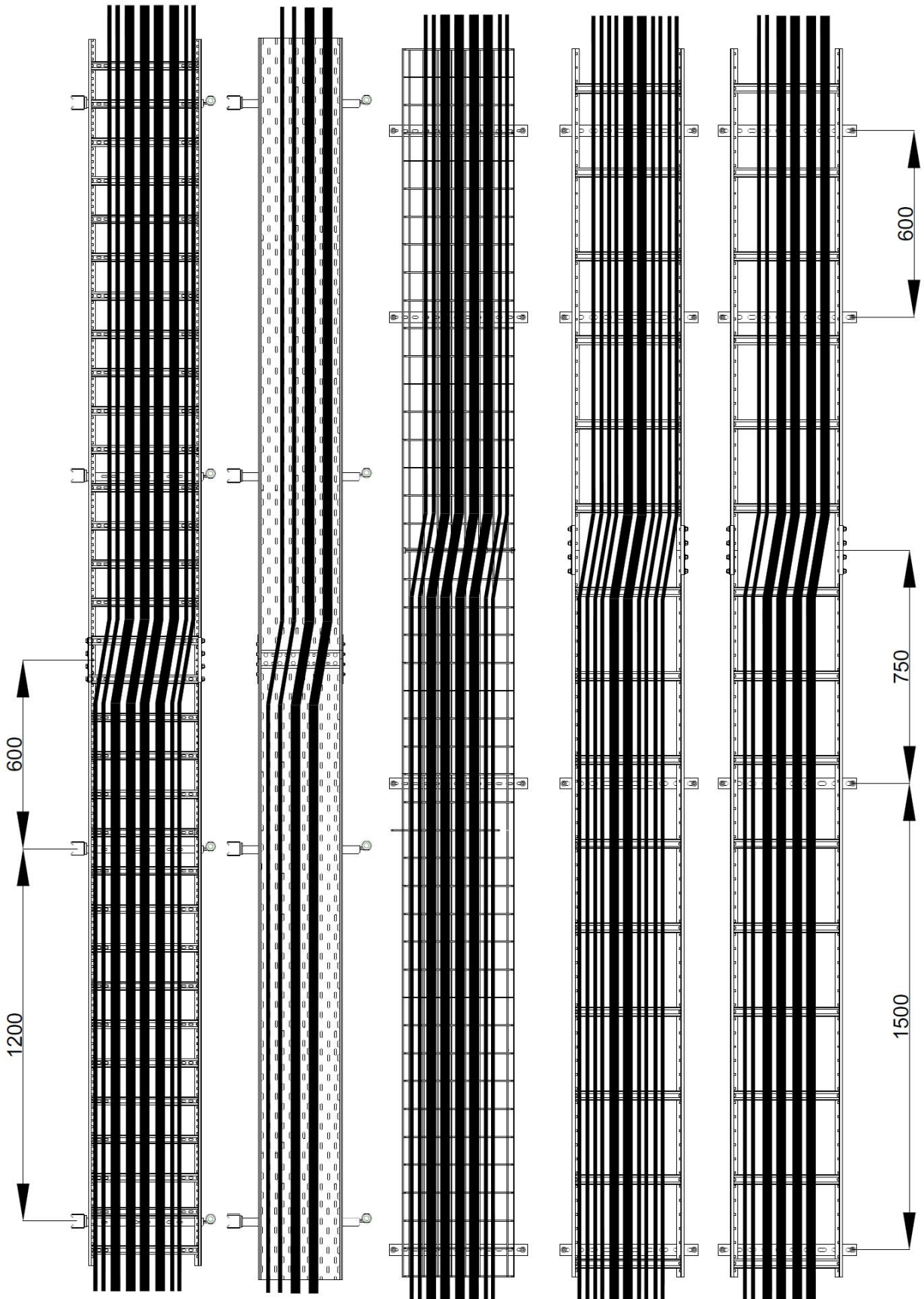

ELPAR-BAKS 21.08.2014



C-C

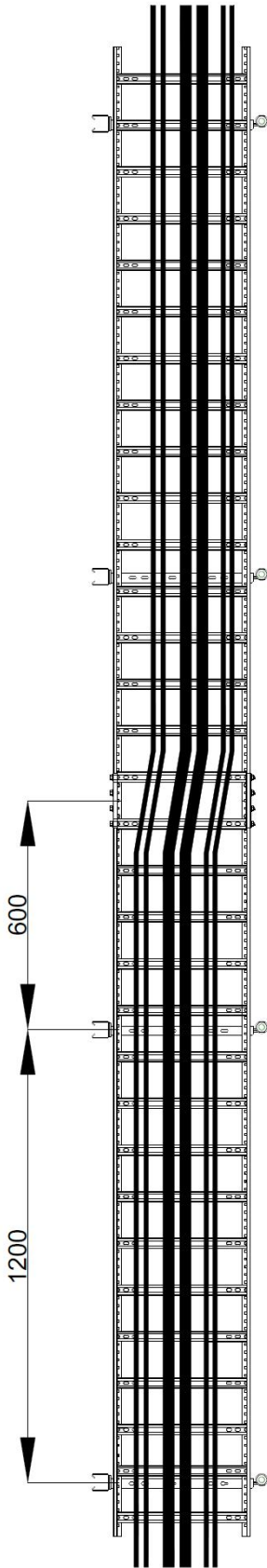

ELPAR-BAKS 21.08.2014



D-D

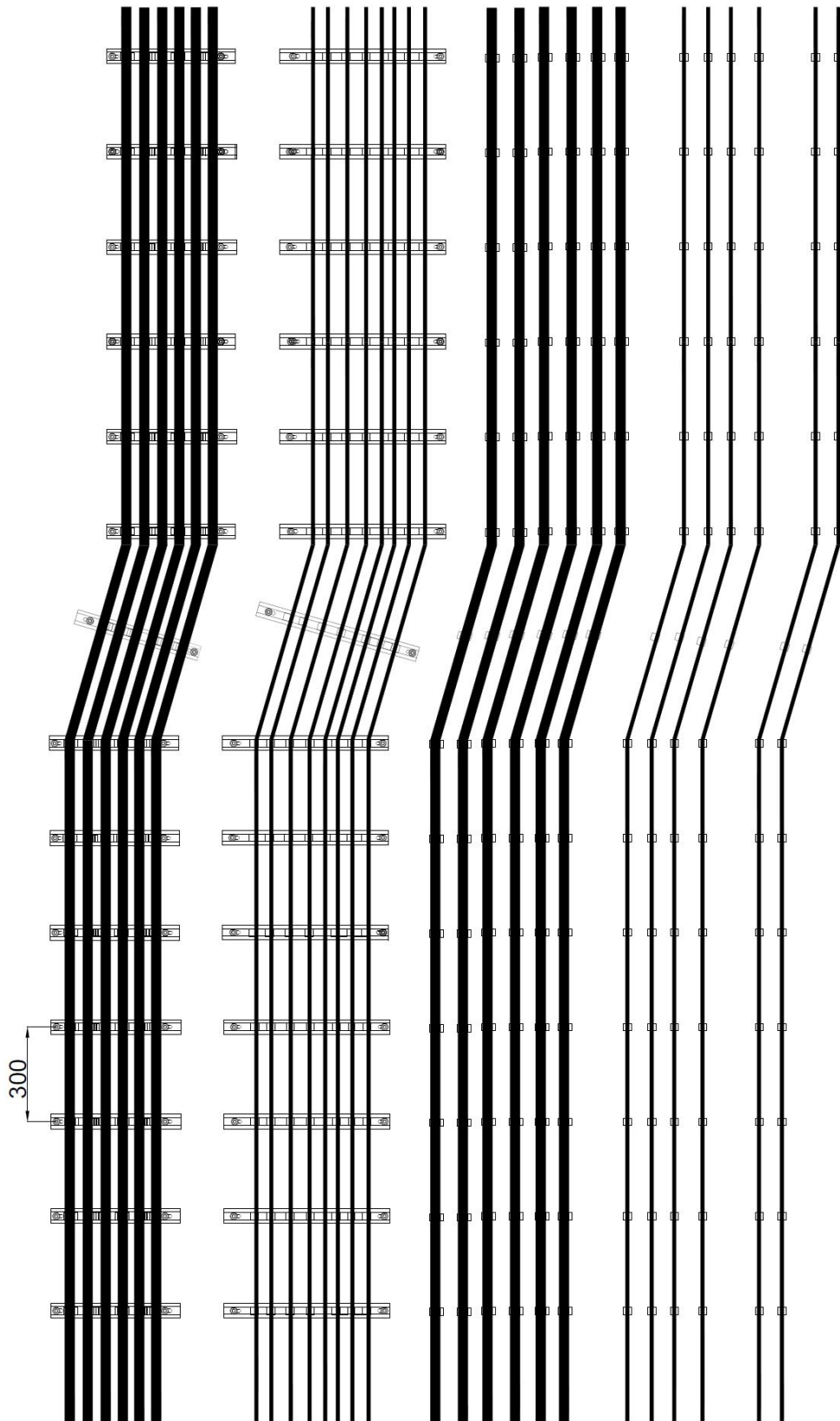

ELPAR-BAKS 21.08.2014



E-E

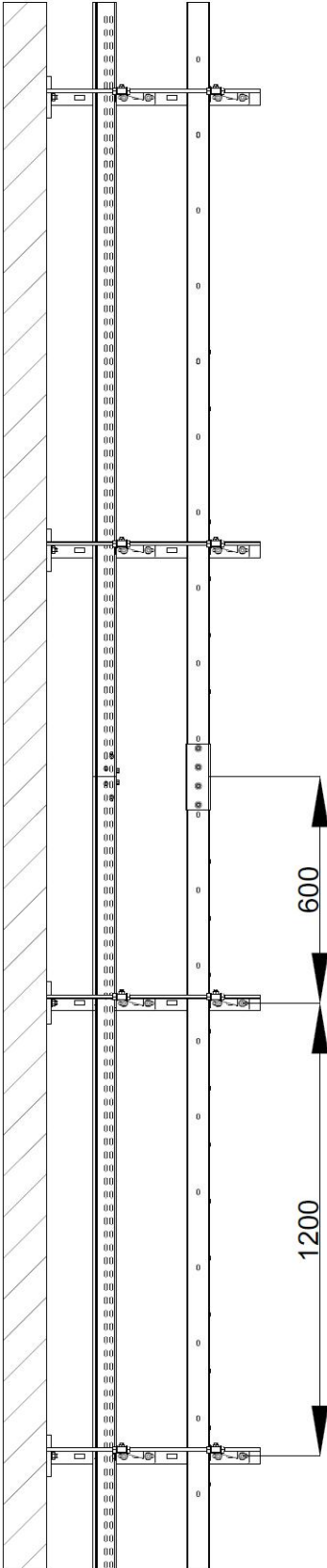

ELPAR-BAKS 21.08.2014



F-F

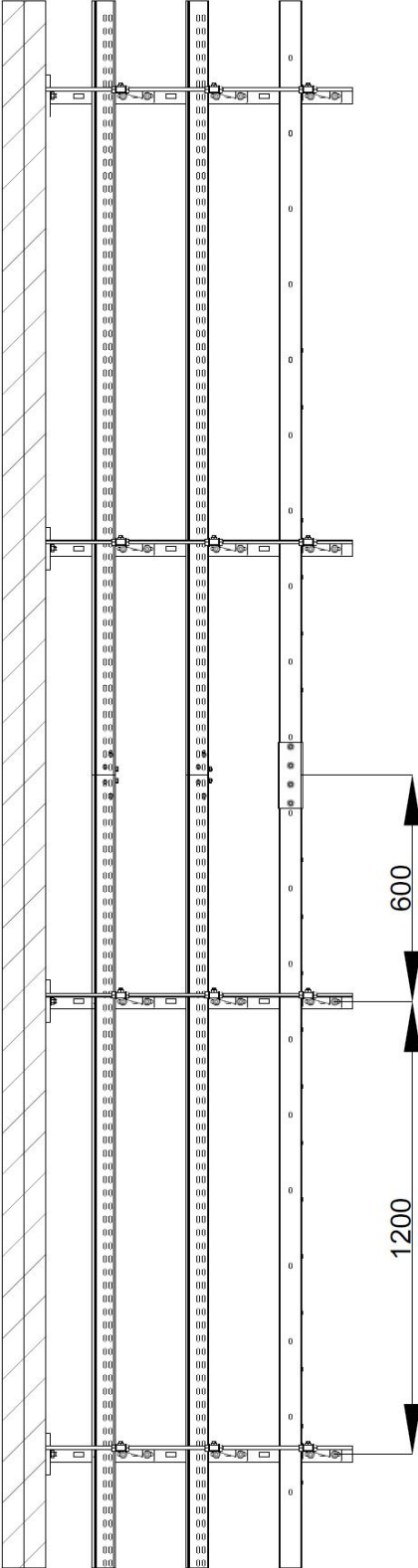

ELPAR-BAKS 21.08.2014



G-G

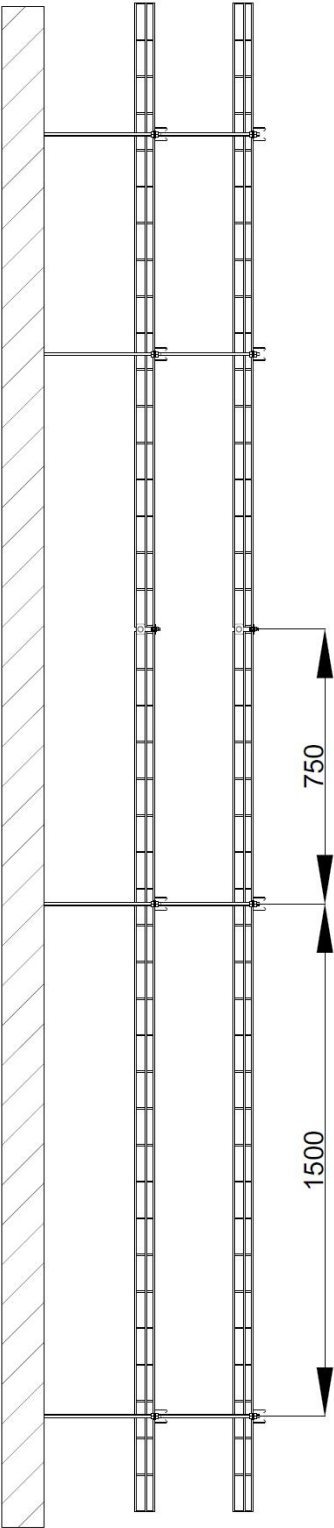

ELPAR-BAKS 21.08.2014



H-H

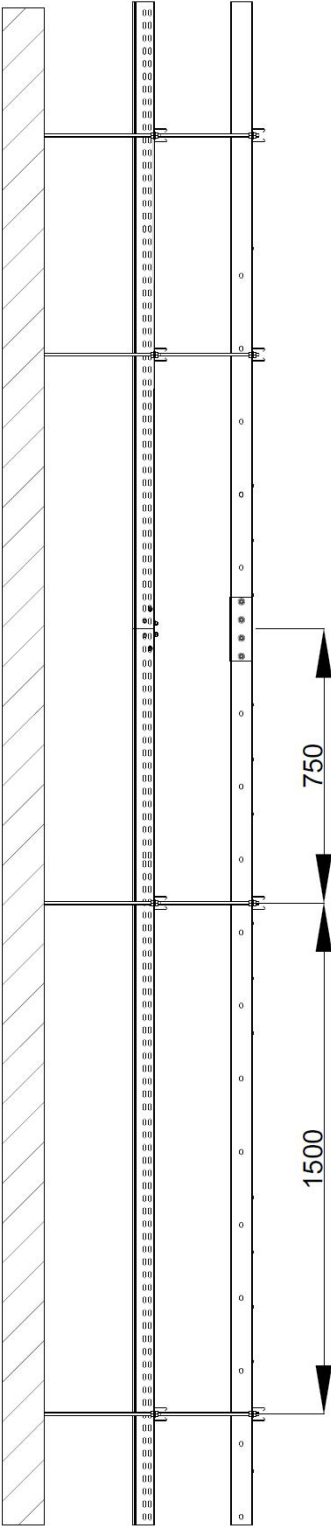

ELPAR-BAKS 21.08.2014



I-I

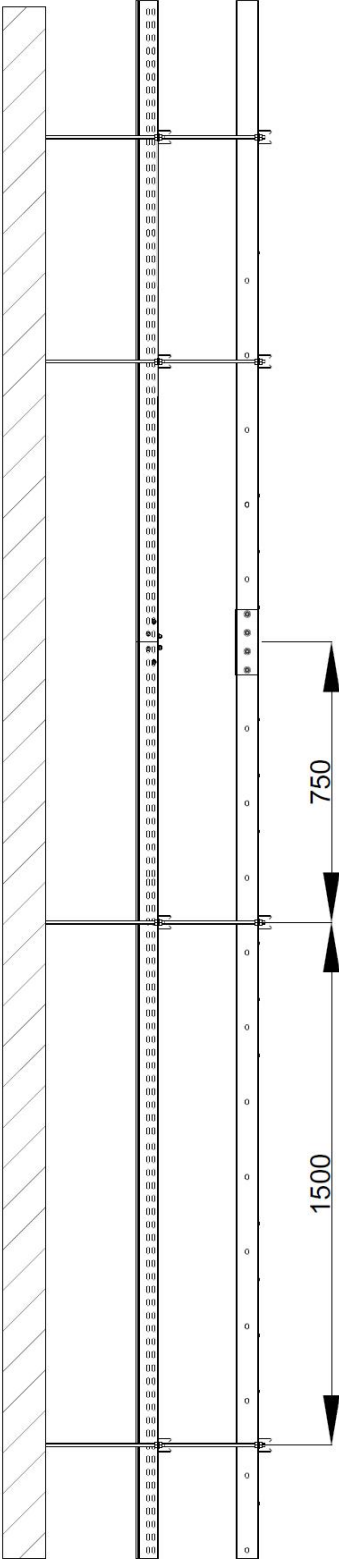

ELPAR-BAKS 21.08.2014



DRAWINGS

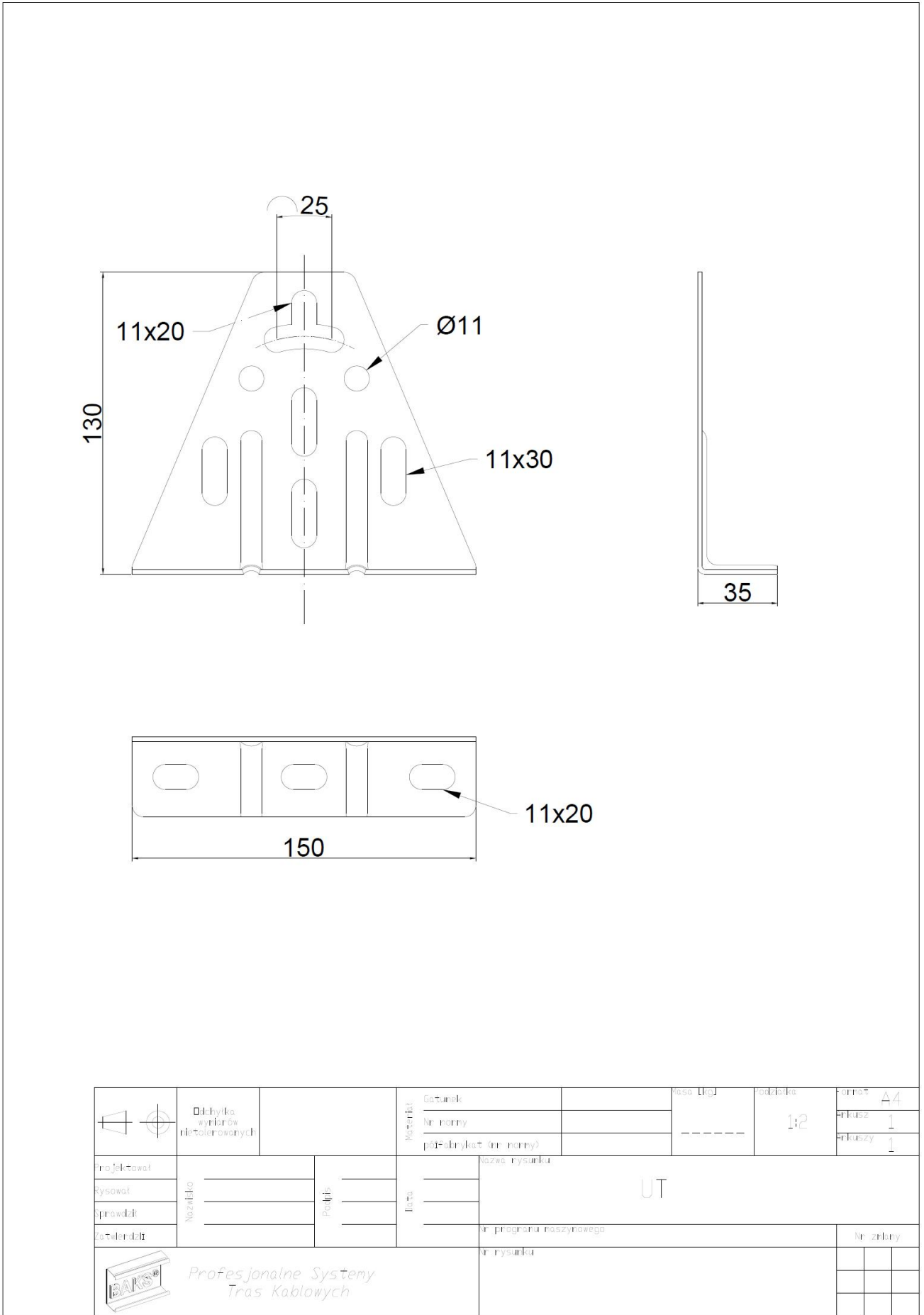

	Długość wybrusów nieolerowanych			Gatunek Nr normy półfabryka? (nr normy)	masa [kg]	grubość 1,2	format A4	
								arkuszy 1 arkuszy 1
projektował	Nazwisko	Podpis	Data	Nazwa rysunku UT				
rysował								
prowadził								
zatwierdził								
					nr programu maszynowego		Nr arkuszy	
					nr rysunku		[] [] []	



7. FINAL PROVISION

- § This report details the method of construction, the test conditions and results obtained when the specific element of construction described herein was following the procedure outlined in EN 1363-1, and where appropriate STN 92 0205. Any significant deviation with respect to size, constructional details, loads, stresses, edge or end conditions other than those allowed under the field of direct application in the relevant test method is not covered by this report.
- § Because of the nature of the fire resistance testing and consequent difficulty in quantifying the uncertainty of measurement of fire resistance, it is not possible to provide a stated degree of accuracy of the result.
- § The test results refer only to the tested subjects. This test report is not an approval of the tested product by the test laboratory or the accreditation body overseeing the laboratory's activities. The test was carried out on testing equipment that is the property of FIRES, s.r.o., Batizovce. Without the written permission of the test laboratory this test report may be copied and/or distributed only as the whole. Any modifications of the test report can be made only by the fire resistance test laboratory FIRES, s.r.o., Batizovce.

Approved by:

Prepared by:

Ing. Štefan Rástocký
leader of the testing laboratory



Bc. Dávid Šubert
technician of the testing laboratory

8. NORMATIVE REFERENCES

EN 1363-1: 2012	Fire resistance tests. Part 1: General requirements
STN 92 0205:2014	Fire behaviour of construction products and building constructions. Circuit integrity maintenance of cable systems. Requirements, testing and classification.
DIN 4102 – 2:1977-09	Fire behaviour of building materials and elements - requirements and testing
DIN 4102 – 12:1998-11	Fire resistance of electric cable systems required to maintain circuit integrity
ZP-27/2008 PAVUS	Test method for determination of functionality class of cables and cable loadbearing constructions - cable circuits in case of fire

THE END OF THE TEST REPORT